

Key: 100

Town of CHATHAM - Fiscal Year 2024

9/7/2023 9:38 am SEQ #: 104

LEGAL

Table with columns: CURRENT OWNER, PARCEL ID, LOCATION, TRANSFER HISTORY, DOS, T, SALE PRICE, BK-PG (Cert). Includes owner OLEARY FAMILY TRUST and parcel 10C-54-OR8.

Table with columns: CLASS, CLASS%, DESCRIPTION, BN ID, BN, CARD. Includes details for SINGLE FAMILY class and renovation history.

LAND

Table with columns: CD, T, AC/SF/UN, Nbhd, Inff1, Inff2, ADJ BASE, SAF, Inff3, Lpi, VC, CREDIT AMT, ADJ VALUE. Includes zoning R20 and assessed values.

DETAILED

Table with columns: TY, QUAL, COND, DIM/NOTE, YB, UNITS, ADJ PRICE, RCNLD. Includes building details like WEST CHATHAM and various unit types.

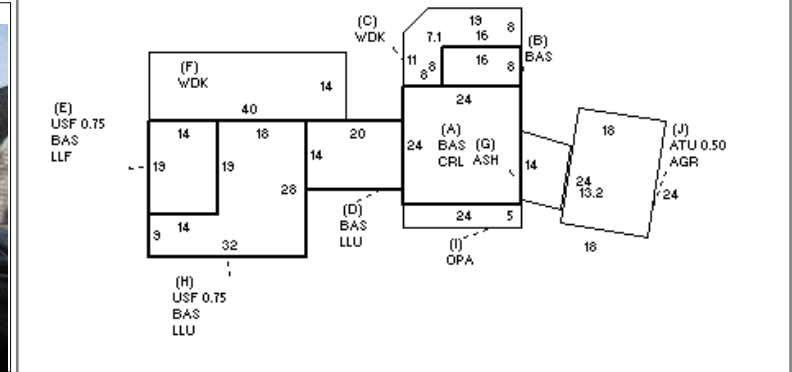

BUILDING

Table with columns: BUILDING, CD, ADJ, DESC, MEASURE, DATE, TCK. Includes building model, style, quality, and frame details.

BLDG COMMENTS: BMF=FAMILY RM, PULL DOWN ATTIC ACCESS /GARAGE, INFO @ DOOR 3/15/22

INDING

Main table with columns: YEAR BLT, SIZE ADJ, ELEMENT, CD, DESCRIPTION, ADJ, S, BAT, T, DESCRIPTION, UNITS, YB, ADJ PRICE, RCN, TOTAL RCN, CONDITION ELEM, CD. Includes building capacity, element details, and RCN breakdown.