

Key: 1072

Town of CHATHAM - Fiscal Year 2024

9/7/2023 9:38 am SEQ #: 1.181

LEGALS

| CURRENT OWNER | | | | | | | | | | PARCEL ID | | | | LOCATION | | | |
|--|--|--|--|--|--|--|--|--|--|------------|---|------------|--|--------------|--|--|--|
| WESTGATE MICHAEL D M & VICK ANN 344 CEDAR ST CHATHAM, MA 02633 | | | | | | | | | | 12B-21-3 | | | | 344 CEDAR ST | | | |
| TRANSFER HISTORY | | | | | | | | | | DOS | T | SALE PRICE | | BK-PG (Cert) | | | |
| WESTGATE MICHAEL D M & VI | | | | | | | | | | 06/19/2007 | A | 1 22120-14 | | | | | |
| WESTGATE MICHAEL DM | | | | | | | | | | 06/17/2007 | A | 1 22120-12 | | | | | |
| WESTGATE MIACHEL DM 1/2 | | | | | | | | | | 06/16/2007 | A | 1 22120-10 | | | | | |

| CLASS | CLASS% | DESCRIPTION | | | BN ID | BN | CARD | |
|----------|------------|---------------|-------------|--------|------------|----|--------|-----|
| 1010 | 100 | SINGLE FAMILY | | | | 1 | 1 of 1 | |
| PMT NO | PMT DT | TY | DESC | AMOUNT | INSP | BY | 1st | % |
| 06-512 | 01/15/2007 | 50 | Meas & List | | | AM | 100 | 100 |
| | 09/21/2006 | 10 | Reroof | 4,000 | 01/15/2007 | | 100 | 100 |
| | 01/08/2002 | 50 | Meas & List | | | JB | 100 | 100 |
| P2001125 | 06/26/2001 | 99 | n/a | | | | 100 | 100 |

LAND

| CD | T | AC/SF/UN | Nbhd | Inf1 | Inf2 | ADJ BASE | SAF | Inf3 | Lpi | VC | CREDIT AMT | ADJ VALUE |
|-----|---|----------|------|------|------|-----------|------|------|------|-----|------------|-----------|
| 100 | S | 40,000 | CH | 1.00 | 100 | 1,007,875 | 1.00 | 100 | 1.00 | R09 | 2.75 | 925,510 |
| 300 | A | 0.071 | CH | 1.00 | 100 | 52,800 | 1.00 | 100 | 1.00 | R09 | 2.75 | 3,750 |

DETACHED

| TOTAL | 43,087 SF | ZONING | R40 | FRNT | 0 | ASSESSED | CURRENT | PREVIOUS |
|-------|-----------|--------|----------|---------|---------|--------------|------------------|------------------|
| Nbhd | CHATHAM | NOTE | | | | LAND | 929,300 | 703,900 |
| Inf1 | 100 | | BUILDING | 446,000 | 406,000 | | | |
| Inf2 | 100 | | DETACHED | 21,800 | 20,800 | | | |
| | | | OTHER | 0 | 0 | | | |
| | | | | | | TOTAL | 1,397,100 | 1,130,700 |

BUILDING

| TY | QUAL | COND | DIM/NOTE | YB | UNITS | ADJ PRICE | RCNLD | PHOTO | 11/28/2012 |
|-----|------|------|---------------|------|-------|-----------|--------|--|------------|
| GUL | A | 1.00 | 30 0.70 26X24 | 1981 | 624 | 50.00 | 21,800 |  | |

| BLDG COMMENTS |
|---------------|
| |

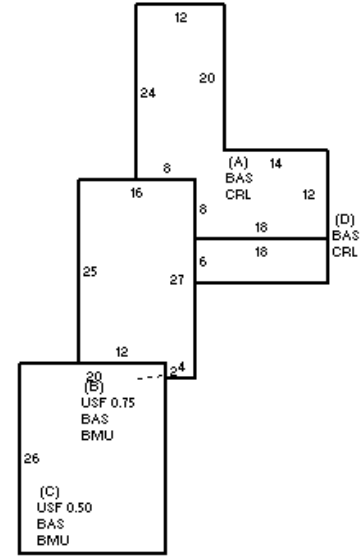

| BUILDING | CD | ADJ | DESC | MEASURE | LIST | REVIEW | 4/8/2021 | APK |
|----------|----|------|-------------------|---------|------|--------|----------|-----|
| MODEL | 1 | | RESIDENTIAL | | | | | |
| STYLE | 21 | 1.00 | ANTIQUE [100%] | | | | | |
| QUALITY | A | 1.00 | AVERAGE [100%] | | | | | |
| FRAME | 1 | 1.00 | WOOD FRAME [100%] | | | | | |

| YEAR BLT | 1830 | SIZE ADJ | 1.000 | ELEMENT | CD | DESCRIPTION | ADJ | S | BAT | T | DESCRIPTION | UNITS | YB | ADJ PRICE | RCN | TOTAL RCN | 602,666 |
|------------|-------|------------|-------|--------------|----|----------------|------|---|-----|---|-----------------|-------|------|-----------|---------|-----------|---------|
| NET AREA | 2,090 | DETAIL ADJ | 1.050 | FOUNDATION | 4 | FLR & WALL | 1.00 | + | CRL | N | CRAWL SPACE | 596 | | 19.81 | 11,807 | | |
| \$NLA(RCN) | \$288 | OVERALL | 1.000 | EXT. COVER | 1 | WOOD SHINGLE | 1.00 | A | BAS | L | BAS AREA | 488 | 1969 | 255.01 | 124,446 | | |
| | | | | ROOF SHAPE | 1 | GABLE | 1.00 | + | BMU | N | BSMT UNFINISHED | 928 | | 66.61 | 61,811 | | |
| | | | | ROOF COVER | 1 | ASPH/CMP SHIN | 1.00 | B | BAS | L | BAS AREA | 408 | 1967 | 255.01 | 104,045 | | |
| | | | | FLOOR COVER | 2 | SOFTWOOD | 1.00 | B | USF | L | UP-STRY FIN | 306 | 1967 | 216.39 | 66,214 | | |
| | | | | INT. FINISH | 1 | PLASTER | 1.00 | C | BAS | L | BAS AREA | 520 | 1830 | 255.01 | 132,606 | | |
| | | | | HEATING/COOL | 11 | HT-WT/COOL AIR | 1.05 | C | USF | L | UP-STRY FIN | 260 | 1830 | 216.38 | 56,260 | | |
| | | | | FUEL SOURCE | 1 | OIL | 1.00 | D | BAS | L | BAS AREA | 108 | 1962 | 255.01 | 27,541 | | |
| | | | | | | | | | F21 | O | FPL 2S 1OP | 1 | | 10,376.00 | 10,376 | | |
| | | | | | | | | | GEN | O | GENERATOR | 1 | | 0.00 | | | |

| CONDITION ELEM | CD |
|----------------|----|
| EXTERIOR | A |
| INTERIOR | A |
| KITCHEN | A |
| BATHS | A |
| HEAT | U |
| ELECT | U |

| EFF.YR/AGE | 1984 / 38 |
|------------|------------|
| COND | 26 26 % |
| FUNC | 0 |
| ECON | 0 |
| DEPR | 26 % GD 74 |

| RCNLD | \$446,000 |
|-------|-----------|
|-------|-----------|