

Key: 1111

Town of CHATHAM - Fiscal Year 2024

9/7/2023 9:38 am SEQ #: 1.221

LEGAL

LAND

DETACHED

BUILDING

CURRENT OWNER				PARCEL ID				LOCATION			
BURKE THOMAS J & ANNE 653 OLD HOMESTEAD HWY SWANZEY, NH 03446-2304				12E-13G-49				42 LINDEN TREE LN			
TRANSFER HISTORY				DOS	T	SALE PRICE	BK-PG (Cert)				
BURKE THOMAS J & ANNE				07/30/1999	99	340,000	(154195)				
CANNATA				01/29/1998	99	99,000	(147342)				

CLASS	CLASS%	DESCRIPTION			BN ID	BN	CARD	
1010	100	SINGLE FAMILY				1	1 of 1	
PMT NO	PMT DT	TY	DESC	AMOUNT	INSP	BY	1st	%
1998003	04/02/2007	50	Meas & List			RRC	100	100
98-004	01/12/1998	99	n/a				100	100
	01/01/1998	1	New Construc	140,000			100	100

CD	T	AC/SF/UN	Nbhd	Inf1	Inf2	ADJ BASE	SAF	Inf3	Lpi	VC	CREDIT AMT	ADJ VALUE
100	S	26,534	WC	1.00	1.00	641,375	1.40	1.00	1.00	R06	1.75	547,510

TOTAL	26,534 SF	ZONING	R40	FRNT	0	ASSESSED	CURRENT	PREVIOUS
Nbhd	WEST CHATHAM	NOTE Lev Tot 26484sf Lcp11696l x/x	LAND		547,500	456,200		
Inf1	100		BUILDING		646,400	587,000		
Inf2	100		DETACHED		0	0		
			OTHER		0	0		
TOTAL					1,193,900	1,043,200		

TY	QUAL	COND	DIM/NOTE	YB	UNITS	ADJ PRICE	RCNLD

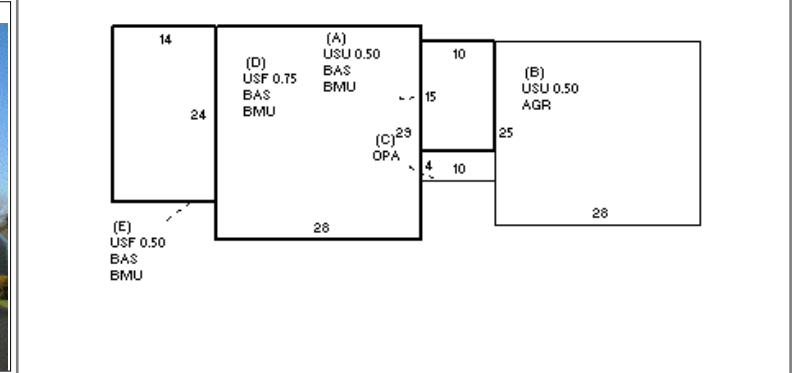

BUILDING	CD	ADJ	DESC	MEASURE		
MODEL	1		RESIDENTIAL	LIST		
STYLE	4	1.00	CAPE [100%]	REVIEW	12/5/2012	SF
QUALITY	+	1.20	PLUS AVE [100%]			
FRAME	1	1.00	WOOD FRAME [100%]			

BLDG COMMENTS

YEAR BLT	1998	SIZE ADJ	1.000	ELEMENT	CD	DESCRIPTION	ADJ	S	BAT	T	DESCRIPTION	UNITS	YB	ADJ PRICE	RCN	TOTAL RCN	818,226																		
NET AREA	2,075	DETAIL ADJ	1.000	FOUNDATION	4	FLR & WALL	1.00	+	BMU	N	BSMT UNFINISHED	1,298		82.27	106,783																				
\$NLA(RCN)	\$394	OVERALL	1.000	EXT. COVER	2	CLAPBOARD	1.00	+	BAS	L	BAS AREA	1,298	1998	283.27	367,686																				
				ROOF SHAPE	1	GABLE	1.00	+	USU	N	UPPER STORY UNF	425		144.33	61,340																				
				ROOF COVER	1	ASPH/CMP SHIN	1.00	B	AGR	N	ATTACHED GARAGE	700		90.93	63,653																				
				FLOOR COVER	16	HARDWD/OTHER	1.00	C	OPA	N	OPEN PORCH	40		91.32	3,653																				
				INT. FINISH	2	DRYWALL	1.00	+	USF	L	UP-STRY FIN	777	1998	240.36	186,763																				
				HEATING/COOL	2	HOT WATER	1.00		PTA	N	PATIO/STOOP	300		21.48	6,444																				
				FUEL SOURCE	2	GAS	1.00		F21	O	FPL 2S 1OP	1		12,451.20	12,451																				
									ODS	O	OUT DOOR SHWR-A	1		1,772.40	1,772																				
				<table border="1"> <tr> <th>EFF.YR/AGE</th> <td colspan="2">2000 / 22</td> </tr> <tr> <th>COND</th> <td>21</td> <td>21 %</td> </tr> <tr> <th>FUNC</th> <td>0</td> <td></td> </tr> <tr> <th>ECON</th> <td>0</td> <td></td> </tr> <tr> <th>DEPR</th> <td>21</td> <td>% GD 79</td> </tr> <tr> <th>RCNLD</th> <td colspan="2">\$646,400</td> </tr> </table>														EFF.YR/AGE	2000 / 22		COND	21	21 %	FUNC	0		ECON	0		DEPR	21	% GD 79	RCNLD	\$646,400	
EFF.YR/AGE	2000 / 22																																		
COND	21	21 %																																	
FUNC	0																																		
ECON	0																																		
DEPR	21	% GD 79																																	
RCNLD	\$646,400																																		
CAPACITY				STORIES	1.75	1.00																													
				ROOMS	0	1.00																													
				BEDROOMS	3	1.00																													
				FULL BATHS	2	1.00																													
				1/2 BATHS	1	1.00																													
				FIXTURES	8	\$7,680																													
				UNITS	1	1.00																													