

Key: 12

Town of CHATHAM - Fiscal Year 2024

9/7/2023 9:38 am SEQ #: 14

LEGAL

LAND

DETACHED

BUILDING

CURRENT OWNER				PARCEL ID				LOCATION			
DAVIS TIMOTHY & SARAH 160 FAIROAKS LN COHASSET, MA 02025-1314				10A-7-9A				78 MOONPENNY LN			
TRANSFER HISTORY				DOS	T	SALE PRICE	BK-PG (Cert)				
DAVIS TIMOTHY & SARAH				01/10/2018	O	886,000	31014-305				
78 MOONPENNY LANE REALTY				04/08/1997	A	330,000	10688-83				

CLASS	CLASS%	DESCRIPTION			BN ID	BN	CARD	
1010	100	SINGLE FAMILY				1	1 of 1	
PMT NO	PMT DT	TY	DESC	AMOUNT	INSP	BY	1st	%
23-231	04/04/2023	3	Renovations	10,000				0
22-647	09/14/2022	3	Renovations	275,000	02/09/2023	NF	40	50
18-828	10/18/2018	3	Renovations	5,799	11/14/2018	APK	100	100
	04/24/2018	98	SALES QUESTI				100	100
18-111	02/06/2018	3	Renovations	155,000	11/14/2018	APK	100	100

CD	T	AC/SF/UN	Nbhd	Inf1	Inf2	ADJ BASE	SAF	Inf3	Lpi	VC	CREDIT AMT	ADJ VALUE
100	S	40,000	CH	1.00	100	1,466,000	1.00	100	1.00	R11	4.00	1,346,190
300	A	0.041	CH	1.00	100	76,800	1.00	100	1.00	R11	4.00	3,150

TOTAL	41,806 SF	ZONING	R40	FRNT	0	ASSESSED		CURRENT	1,349,300	PREVIOUS	1,124,400
Nbhd	CHATHAM	NOTE deeded beach rights to oyster pond river	LAND			1,043,000		828,100			
Inf1	100		BUILDING			1,300		0			
Inf2	100		OTHER			0		0			
			TOTAL			2,393,600		1,952,500			

TY	QUAL	COND	DIM/NOTE	YB	UNITS	ADJ PRICE	RCNLD
SHF	A	1.00	10 0.90 9X11		99	14.11	1,300



BLDG COMMENTS
INTERIOR ESTIMATED PER PLANS 5/12/2023

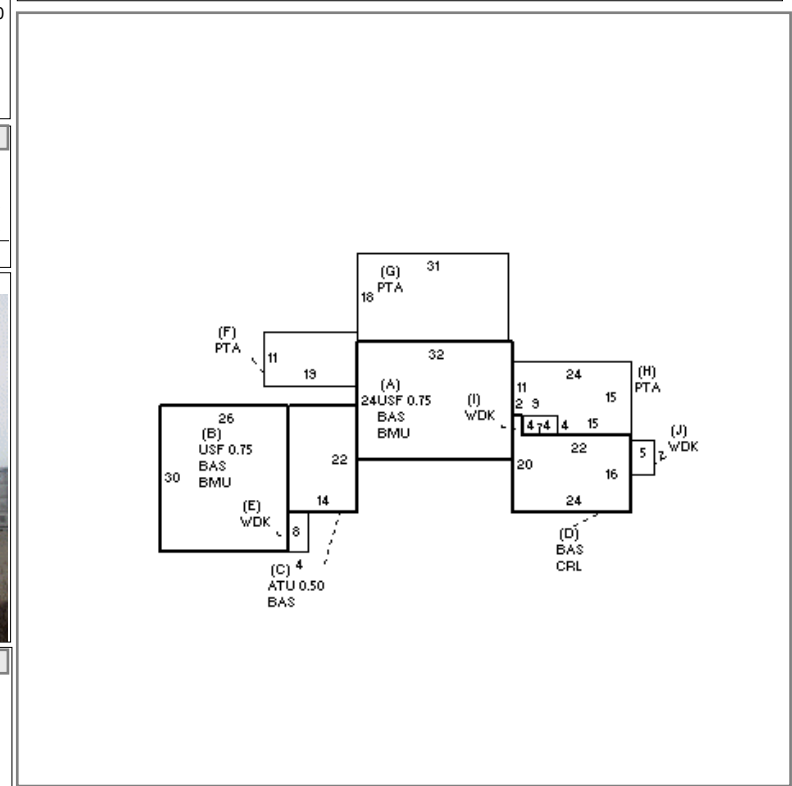

BUILDING	CD	ADJ	DESC	MEASURE	2/9/2023	NF
MODEL	1		RESIDENTIAL	LIST	5/12/2023	EST
STYLE	4	1.00	CAPE [100%]	REVIEW	3/12/2023	EMZ
QUALITY	+	1.20	PLUS AVE [100%]			
FRAME	1	1.00	WOOD FRAME [100%]			

YEAR BLT	1972	SIZE ADJ	1.000	ELEMENT	CD	DESCRIPTION	ADJ	S	BAT	T	DESCRIPTION	UNITS	YB	ADJ PRICE	RCN
NET AREA	3,409	DETAIL ADJ	1.050	FOUNDATION	4	FLR & WALL	1.00	+	BMU	N	BSMT UNFINISHED	1,548		77.17	119,462
\$NLA(RCN)	\$333	OVERALL	1.000	EXT. COVER	1	WOOD SHINGLE	1.00	A	USF	L	UP-STRY FIN	576	1972	242.68	139,781
				ROOF SHAPE	1	GABLE	1.00	B	USF	L	UP-STRY FIN	585	2022	242.68	141,966
				ROOF COVER	1	ASPH/CMP SHIN	1.00	+	BAS	L	BAS AREA	2,248	1972	286.00	642,917
				FLOOR COVER	1	HARDWOOD	1.00	C	ATU	N	UNFIN ATTIC	154		94.20	14,507
				INT. FINISH	2	DRYWALL	1.00	D	CRL	N	CRAWL SPACE	392		22.95	8,998
				HEATING/COOL	11	HT-WT/COOL AIR	1.05	+	WDK	N	WOOD DECK	95		70.08	6,658
				FUEL SOURCE	1	OIL	1.00	+	PTA	N	PATIO/STOOP	1,091		21.48	23,435
									BMG	O	BSMT GARAGE	2		3,323.40	6,647
									F21	O	FPL 2S 1OP	1		12,451.20	12,451
									ODS	O	OUT DOOR SHWR-A	1		1,772.40	1,772

TOTAL RCN	1,133,713
CONDITION ELEM	CD
EXTERIOR	V
INTERIOR	V
KITCHEN	V
BATHS	V
HEAT	U
ELECT	U
EFF.YR/AGE	2022 / 0
COND	0 0 %
FUNC	8 UC
ECON	0
DEPR	8 % GD 92
RCNLD	\$1,043,000