

Key: 131

Town of CHATHAM - Fiscal Year 2024

9/7/2023 9:38 am SEQ #: 135

LEGAL

LAND

DETACHED

BUILDING

| CURRENT OWNER | | | | PARCEL ID | | | | LOCATION | | | |
|--|--|--|--|-------------|----|------------|--------------|----------------------|--|--|--|
| 88 MEADOWVIEW ROAD SOUTH RE TRUST CREONTE JOSEPH A & MARGARET B TRSTES 9 WASHBURN AVE WELLESLEY HILLS, MA 02481 | | | | 10D-14-S19A | | | | 88 MEADOW VIEW RD SO | | | |
| TRANSFER HISTORY | | | | DOS | T | SALE PRICE | BK-PG (Cert) | | | | |
| 88 MEADOWVIEW ROAD SOUTH | | | | 03/25/2022 | QS | 3,150,000 | 35001-61 | | | | |
| MEADOWVIEW LANDING LLC | | | | 02/03/2021 | P | 750,000 | 33756-220 | | | | |
| PHILIP A CHRISTOPHE TRUST | | | | 06/22/1984 | A | 100 | 4154-308 | | | | |

| CLASS | CLASS% | DESCRIPTION | | | BN ID | BN | CARD | |
|--------|------------|---------------|--------------|---------|------------|-----|--------|-----|
| 1010 | 100 | SINGLE FAMILY | | | | 1 | 1 of 1 | |
| PMT NO | PMT DT | TY | DESC | AMOUNT | INSP | BY | 1st | % |
| 21-691 | 04/19/2022 | 98 | SALES QUESTI | | | | 100 | 100 |
| 21-338 | 08/04/2021 | 13 | SH.MTL/FHAIR | 29,000 | 04/28/2022 | NF | 100 | 100 |
| | 04/21/2021 | 1 | New Construc | 484,106 | 04/05/2023 | NF | 100 | 100 |
| | 02/09/2021 | 61 | Inspect/Revi | | | APK | 100 | 100 |
| | 02/09/2021 | 71 | ABC | | | | 100 | 100 |

| CD | T | AC/SF/UN | Nbhd | Inf1 | Inf2 | ADJ BASE | SAF | Inf3 | Lpi | VC | CREDIT AMT | ADJ VALUE | | | |
|-----|---|----------|------|------|------|----------|------|-----------|------|-----|------------|-----------|------|--|---------|
| 100 | S | 26,500 | WC | 1.00 | 100 | 1.00 | 1.00 | 1,095,835 | 1.40 | ADK | 1.30 | VW3 | 2.30 | | 935,190 |

| TOTAL | 26,500 SF | ZONING | R20 | FRNT | 0 | ASSESSED | CURRENT | PREVIOUS |
|-------|--------------|---------------------|--------------|------------------|------------------|----------|---------|----------|
| Nbhd | WEST CHATHAM | NOTE deeded dock | LAND | 935,200 | 779,300 | | | |
| Inf1 | 100 | | BUILDING | 2,146,300 | 961,600 | | | |
| Inf2 | 100 | | DETACHED | 5,200 | 4,000 | | | |
| | | | OTHER | 0 | 0 | | | |
| | | | TOTAL | 3,086,700 | 1,744,900 | | | |

| TY | QUAL | COND | DIM/NOTE | YB | UNITS | ADJ PRICE | RCNLD | | |
|-----|------|------|----------|------|--------------|-----------|-------|-------|-------|
| WDK | V | 1.50 | 10 | 0.90 | 13X18 ROOFTO | 2021 | 234 | 24.90 | 5.200 |



BLDG COMMENTS
BMF=FAMILY RM/BATH
INTERIOR ESTIMATED PER PLANS 4/28/2022

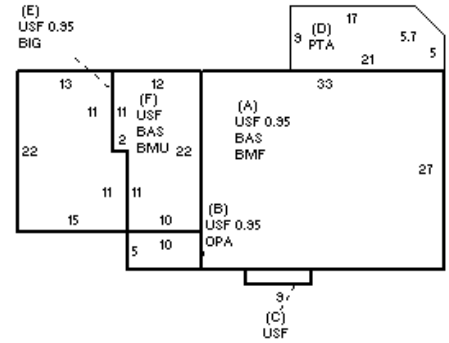

| BUILDING | CD | ADJ | DESC | MEASURE | 4/28/2022 | NF |
|----------|----|------|-------------------|---------|-----------|-----|
| MODEL | 1 | | RESIDENTIAL | LIST | 4/28/2022 | EST |
| STYLE | 19 | 1.30 | NEW STYLE [100%] | REVIEW | 4/19/2023 | EMZ |
| QUALITY | V | 2.35 | VERY GOOD [100%] | | | |
| FRAME | 1 | 1.00 | WOOD FRAME [100%] | | | |

| YEAR BLT | 2021 | SIZE ADJ | 1.000 | ELEMENT | CD | DESCRIPTION | ADJ | S | BAT | T | DESCRIPTION | UNITS | YB | ADJ PRICE | RCN |
|------------|-------|------------|--------------|------------|---------------|--------------|---------|------|-----|-----------------|-----------------|------------|-----------|-----------|---------|
| NET AREA | 2,580 | DETAIL ADJ | 1.339 | FOUNDATION | 4 | FLR & WALL | 1.00 | A | BMF | N | BSMT FINISH-SEP | 891 | | 255.21 | 227,393 |
| \$NLA(RCN) | \$840 | OVERALL | 1.000 | EXT. COVER | 1 | WOOD SHINGLE | 1.00 | + | BAS | L | BAS AREA | 1,133 | 2021 | 739.62 | 837,991 |
| CAPACITY | | | UNITS | ADJ | ROOF SHAPE | 3 | GAMBREL | 1.00 | B | OPA | N | OPEN PORCH | | 178.84 | 8,942 |
| STORIES | 1.95 | 1.00 | ROOF COVER | 1 | ASPH/CMP SHIN | 1.00 | + | USF | L | UP-STRY FIN | 1,447 | 2021 | 627.59 | 908,127 | |
| ROOMS | 7 | 1.00 | FLOOR COVER | 1 | HARDWOOD | 1.00 | D | PTA | N | PATIO/STOOP | 181 | | 42.07 | 7,614 | |
| BEDROOMS | 3 | 1.00 | INT. FINISH | 2 | DRYWALL | 1.00 | E | BIG | N | BUILT-IN GARAGE | 308 | | 196.68 | 60,578 | |
| FULL BATHS | 4 | 1.00 | HEATING/COOL | 9 | WARM/COOL AIR | 1.03 | F | BMU | N | BSMT UNFINISHED | 242 | | 212.63 | 51,456 | |
| 1/2 BATHS | 1 | 1.00 | FUEL SOURCE | 2 | GAS | 1.00 | | GEN | O | GENERATOR | 1 | | 0.00 | | |
| FIXTURES | 19 | \$47,830 | | | | | | GFP | O | GAS LOG/FP/E FP | 1 | | 14,621.70 | 14,622 | |
| UNITS | 1 | 1.00 | | | | | | ODS | O | OUT DOOR SHWR-A | 1 | | 3,471.00 | 3,471 | |

| TOTAL RCN | 2,168,023 |
|----------------|-------------|
| CONDITION ELEM | CD |
| EXTERIOR | A |
| INTERIOR | A |
| KITCHEN | A |
| BATHS | A |
| HEAT | A |
| ELECT | A |
| EFF.YR/AGE | 2021 / 1 |
| COND | 1 1 % |
| FUNC | 0 |
| ECON | 0 |
| DEPR | 1 % GD 99 |
| RCNLD | \$2,146,300 |