

Key: 1590

Town of CHATHAM - Fiscal Year 2024

9/7/2023 9:38 am SEQ #: 1.727

LEGAL

CURRENT OWNER				PARCEL ID				LOCATION			
111 INDEPENDENCE LANE REALTY TRUST FLEISCHMANN JONATHAN L & RUTH S TRSTES 8 ANGIER RD LEXINGTON, MA 02173				13B-33C-DC7				111 INDEPENDENCE LN			
TRANSFER HISTORY				DOS	T	SALE PRICE	BK-PG (Cert)				
111 INDEPENDENCE LANE REA				09/11/2008	A	1	23150-93				
FLEISCHMANN JONATHAN L &				06/15/2001	QS	600,000	13940-217				
SMITH JR THOEDORE S				05/08/1992	QS	315,000	8010-302				

CLASS	CLASS%	DESCRIPTION			BN ID	BN	CARD	
1010	100	SINGLE FAMILY				1	1 of 1	
PMT NO	PMT DT	TY	DESC	AMOUNT	INSP	BY	1st	%
12-554	11/27/2012	99	n/a	2,000	04/03/2014	MR	100	100
	02/20/2004	50	Meas & List			RRC	100	100
P2003138	04/03/2003	99	n/a	22,000			100	100
03-138	04/03/2003	99	n/a	22,000			100	100
1983003	01/05/1983	99	n/a				100	100

LAND

CD	T	AC/SF/UN	Nbhd	Inf1	Inf2	ADJ BASE	SAF	Inf3	Lpi	VC	CREDIT AMT	ADJ VALUE
100	S	23,620	CH	1.00	100	1.00	100	1.00	R11	4.00		1,227,520

TOTAL	23,620 SF	ZONING	R40	FRNT	0	ASSESSED	CURRENT	PREVIOUS
Nbhd	CHATHAM	NOTE	LAND		1,227,500	1,022,900		
Inf1	100		BUILDING		646,000	587,900		
Inf2	100		DETACHED		0	0		
			OTHER		0	0		
TOTAL					1,873,500	1,610,800		

DETACHED

TY	QUAL	COND	DIM/NOTE	YB	UNITS	ADJ PRICE	RCNLD

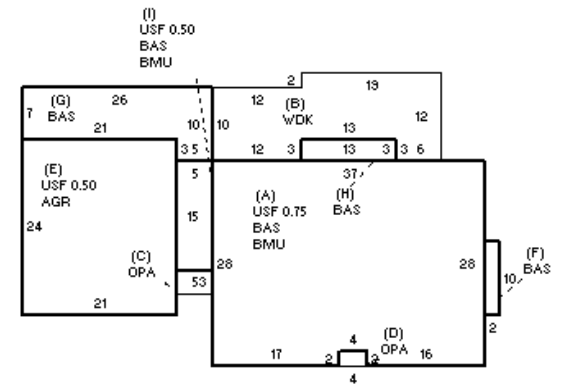

BUILDING

BUILDING	CD	ADJ	DESC	MEASURE		
MODEL	1		RESIDENTIAL	LIST REVIEW	4/7/2014	MR
STYLE	4	1.00	CAPE [100%]			
QUALITY	+	1.20	PLUS AVE [100%]			
FRAME	1	1.00	WOOD FRAME [100%]			

BLDG COMMENTS	

G

YEAR BLT	1983	SIZE ADJ	1.000	ELEMENT	CD	DESCRIPTION	ADJ	S	BAT	T	DESCRIPTION	UNITS	YB	ADJ PRICE	RCN	TOTAL RCN	849,972
NET AREA	2,420	DETAIL ADJ	1.030	FOUNDATION	4	FLR & WALL	1.00	+	BMU	N	BSMT UNFINISHED	1,103		85.02	93,781		
\$NLA(RCN)	\$351	OVERALL	1.000	EXT. COVER	1	WOOD SHINGLE	1.00	+	USF	L	UP-STRY FIN	809	1983	248.63	201,145		
				ROOF SHAPE	1	GABLE	1.00	B	WDK	N	WOOD DECK	309		70.08	21,655		
				ROOF COVER	1	ASPH/CMP SHIN	1.00	+	OPA	N	OPEN PORCH	23		91.30	2,100		
				FLOOR COVER	1	HARDWOOD	1.00	E	AGR	N	ATTACHED GARAGE	504		93.85	47,303		
				INT. FINISH	2	DRYWALL	1.00	E	USF	L	UP-STRY FIN	252	2003	248.63	62,656		
				HEATING/COOL	9	WARM/COOL AIR	1.03	+	BAS	L	BAS AREA	1,359	1983	293.02	398,209		
				FUEL SOURCE	1	OIL	1.00		F21	O	FPL 2S 1OP	1		12,451.20	12,451		
									ODS	O	OUT DOOR SHWR-A	1		1,772.40	1,772		
																CONDITION ELEM	CD
																EXTERIOR	
																INTERIOR	
																KITCHEN	
																BATHS	
																HEAT	
																ELECT	
																EFF.YR/AGE	1991 / 31
																COND	24 24 %
																FUNC	0
																ECON	0
																DEPR	24 % GD 76
																RCNLD	\$646,000