

Key: 1897

Town of CHATHAM - Fiscal Year 2024

9/7/2023 9:38 am SEQ #: 2.062

LEGAL

CURRENT OWNER				PARCEL ID				LOCATION			
MISTY MEADOW RESIDENCES LLC 390 ORLEANS RD N CHATHAM, MA 02650				13H-1-NE				81 MISTY MEADOW LN			
TRANSFER HISTORY				DOS	T	SALE PRICE	BK-PG (Cert)				
MISTY MEADOW RESIDENCES L				07/30/2019	U	1,600,000	(220099)				
MISTY MEADOW LANE RT				11/08/2001	N	1,725,000	(163350)				
ROCHETTE RICHARD J				11/03/1992	B	8336-289					

CLASS	CLASS%	DESCRIPTION			BN ID	BN	CARD
1110	100	4 TO 8 UNITS				1	1 of 1
PMT NO	PMT DT	TY	DESC	AMOUNT	INSP	BY	1st %
	02/27/2023	72	I&E				100 100
	03/04/2020	72	I&E				100 100
	06/10/2009	62	-			CE	100 100

LAND

CD	T	AC/SF/UN	Nbhd	Inf1	Inf2	ADJ BASE	SAF	Inf3	Lpi	VC	CREDIT AMT	ADJ VALUE
103	S	43,560	CI	1.00	100	375,210	1.00	100	1.00	OUT	0.90	375,210
303	A	0.798	CI	1.00	100	53,370	1.00	100	1.00	OUT	0.90	42,590

TOTAL	1.798 Acres		ZONING	R40	FRNT	0	ASSESSED	CURRENT	PREVIOUS
Nbhd	COMMERCIAL		NOTE				LAND	417,800	379,800
Inf1	100			LAND BUILDING	1,321,300	1,202,800			
Inf2	100			DETACHED	20,300	19,400			
				OTHER	0	0			
				<b>TOTAL</b>	<b>1,759,400</b>	<b>1,602,000</b>			

DETACHED

TY	QUAL	COND	DIM/NOTE	YB	UNITS	ADJ PRICE	RCNLD	PHOTO
CPD	A	1.00	20 0.80	1988	1,600	14.01	17,900	11/19/2012
APV	A	1.00	70 0.30	1987	4,000	2.00	2,400	

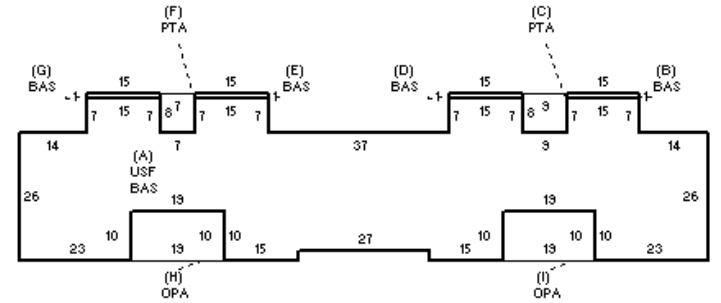

BLDG COMMENTS
PORT SIDE 8 APTS (9-16)

BUILDING

BUILDING	CD	ADJ	DESC	MEASURE	REVIEW	11/19/2012	DF
MODEL	1		RESIDENTIAL				
STYLE	20	0.85	APARTMENTS [100%]	LIST			
QUALITY	A	1.00	AVERAGE [100%]	REVIEW			
FRAME	1	1.00	WOOD FRAME [100%]				

YEAR BLT	1963	SIZE ADJ	1.000	ELEMENT	CD	DESCRIPTION	ADJ	S	BAT	T	DESCRIPTION	UNITS	YB	ADJ PRICE	RCN	TOTAL RCN	1,809,988
NET AREA	7,484	DETAIL ADJ	0.850	FOUNDATION	4	FLR & WALL	1.00	+	BAS	L	BAS AREA	3,712	1963	199.26	739,642		
\$NLA(RCN)	\$242	OVERALL	1.100	EXT. COVER	1	WOOD SHINGLE	1.00	A	USF	L	UP-STRY FIN	3,652	1963	169.08	617,465		
CAPACITY				ROOF SHAPE	1	GABLE	1.00	+	PTA	N	PATIO/STOOP	128		19.69	2,520		
STORIES	2	ADJ	1.00	ROOF COVER	1	ASPH/CMP SHIN	1.00	+	OPA	N	OPEN PORCH	380		83.71	31,811		
ROOMS	0		1.00	FLOOR COVER	36	CARPET/OTHER	1.00		BAS	L	BAS AREA	120	1963	199.26	23,911		
BEDROOMS	9		1.00	INT. FINISH	2	DRYWALL	1.00		BMU	N	BSMT UNFINISHED	3,116		67.14	209,218		
FULL BATHS	8		1.00	HEATING/COOL	5	ELECTRIC BB	1.00		OPA	N	OPEN PORCH	620		83.71	51,900		
1/2 BATHS	4		1.00	FUEL SOURCE	3	ELECTRIC	1.00		F21	O	FPL 2S 1OP	4		11,413.60	45,654		
FIXTURES	32	\$23,936							F22	O	FPL 2S 2OP	4		15,983.00	63,932		
UNITS	8	1.10															

CONDITION ELEM	CD
EXTERIOR	
INTERIOR	
KITCHEN	
BATHS	
HEAT	
ELECT	
EFF.YR/AGE	1980 / 42
COND	27 27 %
FUNC	0
ECON	0
DEPR	27 % GD 73
RCNLD	\$1,321,300