

Key: 2118

Town of CHATHAM - Fiscal Year 2024

9/7/2023 9:38 am SEQ #: 2.290

LEGAL

CURRENT OWNER				PARCEL ID				LOCATION			
RUSSELL DANIEL & HEIDI 45 BRIDGE ST CHATHAM, MA 02633				14A-11A-93				45 BRIDGE ST			
TRANSFER HISTORY				DOS	T	SALE PRICE	BK-PG (Cert)				
RUSSELL DANIEL & HEIDI				04/09/2018	B		1 (215840)				
45 BRIDGE LLC				03/09/2017	O	1,350,000	(212255)				
BYRNE RESIDUARY TRUST				02/06/1992	A		1 (125676)				

CLASS	CLASS%	DESCRIPTION			BN ID	BN	CARD	
1010	100	SINGLE FAMILY				1	1 of 1	
PMT NO	PMT DT	TY	DESC	AMOUNT	INSP	BY	1st	%
SS20-07	07/18/2018	20	Splits/Land		07/18/2018	APK	100	100
17-363	05/30/2017	3	Renovations	17,000	06/21/2018	MR	100	100
17-288	04/25/2017	1	New Construc	379,000	06/21/2018	MR	100	100
17-259	04/12/2017	9	Foundation	22,000	06/21/2018	MR	100	100
17-232	04/05/2017	5	Demolitions	7,500	10/24/2017	APK	100	100

LAND

CD	T	AC/SF/UN	Nbhd	Inf1	Inf2	ADJ BASE	SAF	Inf3	Lpi	VC	CREDIT AMT	ADJ VALUE
100	S	40,000	CH	1.00	100	3,481,750	1.00	100	1.00	PF3	9.50	3,197,200
300	A	0.385	CH	1.00	10	18,240	1.00	100	1.00	PF3	9.50	7,020

DETAILED

TOTAL	1.303 Acres		ZONING	R40	FRNT	0	ASSESSED	CURRENT	PREVIOUS
Nbhd	CHATHAM		NOTE River Front Ocean View	LAND			3,204,200	3,091,600	
Inf1	100			BUILDING			1,196,800	1,080,900	
Inf2	100			DETACHED			0	0	
			OTHER			0	0		
			TOTAL			4,401,000	4,172,500		

BUILDING

BUILDING	CD	ADJ	DESC	MEASURE	6/21/2018	MR
MODEL	1		RESIDENTIAL	LIST	6/21/2018	EST
STYLE	5	1.00	COLONIAL [100%]	REVIEW	7/3/2018	TD
QUALITY	G	1.55	GOOD [100%]			
FRAME	1	1.00	WOOD FRAME [100%]			



TY	QUAL	COND	DIM/NOTE	YB	UNITS	ADJ PRICE	RCNLD
PHOTO 01/12/2018							
BLDG COMMENTS							

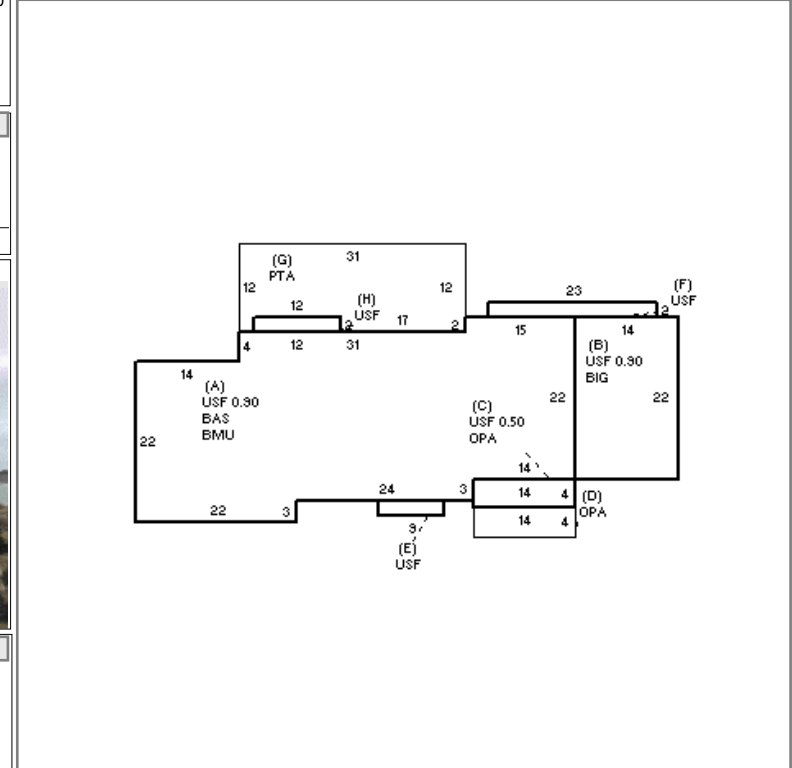

G

YEAR BLT	2017	SIZE ADJ	1.000	ELEMENT	CD	DESCRIPTION	ADJ	S	BAT	T	DESCRIPTION	UNITS	YB	ADJ PRICE	RCN	TOTAL RCN	1,259,757
NET AREA	3,011	DETAIL ADJ	1.030	FOUNDATION	4	FLR & WALL	1.00	A	BMU	N	BSMT UNFINISHED	1,378		105.07	144,793		
\$NLA(RCN)	\$418	OVERALL	1.000	EXT. COVER	1	WOOD SHINGLE	1.00	A	BAS	L	BAS AREA	1,378	2017	367.61	506,563		
				ROOF SHAPE	1	GABLE	1.00	B	BIG	N	BUILT-IN GARAGE	308		129.73	39,956		
				ROOF COVER	1	ASPH/CMP SHIN	1.00	+	OPA	N	OPEN PORCH	112		117.95	13,211		
				FLOOR COVER	1	HARDWOOD	1.00	+	USF	L	UP-STRY FIN	1,633	2017	311.93	509,378		
				INT. FINISH	2	DRYWALL	1.00	G	PTA	N	PATIO/STOOP	348		27.74	9,655		
				HEATING/COOL	9	WARM/COOL AIR	1.03		GEN	O	GENERATOR	1		0.00			
				FUEL SOURCE	2	GAS	1.00		GFP	O	GAS LOG/FP/E FP	1		9,644.10	9,644		
									ODS	O	OUT DOOR SHWR-A	1		2,289.40	2,289		

CONDITION ELEM	CD
EXTERIOR	A
INTERIOR	A
KITCHEN	A
BATHS	A
HEAT	A
ELECT	A

EFF. YR/AGE	2017 / 5
COND	5 5 %
FUNC	0
ECON	0
DEPR	5 % GD 95
RCNLD	\$1,196,800