

Key: 2230

Town of CHATHAM - Fiscal Year 2024

9/7/2023 9:38 am SEQ #: 2.421

LEG
AL
LAND

CURRENT OWNER				PARCEL ID				LOCATION				
NYMAN ERIC C & LAURA JH 295 LAUREL AVE PROVIDENCE, RI 02906				14C-23-G7				203 CROSS ST				
TRANSFER HISTORY				DOS	T	SALE PRICE	BK-PG (Cert)					
NYMAN ERIC C & LAURA JH				05/29/2014	QS	1,850,000	28171-268					
203 CROSS ST LLC				12/20/2012	R	1	26970-194					
TUTRONE AMY AM				11/27/2012	A	1	26890-222					
CD	T	AC/SF/UN	Nbhd	Inf1	Inf2	ADJ BASE	SAF	Inf3	Lpi	VC	CREDIT AMT	ADJ VALUE
100	S	28,000	CH	1.00	100	1,466,000	1.34	100	1.00	R11	4.00	1,262,820

CLASS	CLASS%	DESCRIPTION			BN ID	BN	CARD	
1010	100	SINGLE FAMILY				1	1 of 1	
PMT NO	PMT DT	TY	DESC	AMOUNT	INSP	BY	1st	%
15-356	10/06/2015	2	Additions	7,500		RRC	100	100
	06/23/2015	99	n/a				100	100
	02/18/2007	50	Meas & List				100	100
05-595	03/24/2006	50	Meas & List	85,000	02/18/2007	RRC	100	100
	12/07/2005	3	Renovations				100	100

DE
TA
CH
ED

TOTAL	28,000 SF	ZONING	R40	FRNT	0	ASSESSED	CURRENT	PREVIOUS
Nbhd	CHATHAM	NOTE				LAND	1,262,800	1,052,300
Inf1	100		BUILDING	1,192,800	1,086,400			
Inf2	100		DETACHED	0	0			
			OTHER	0	0			
			TOTAL	2,455,600	2,138,700			

BU
IL
D
ING

TY	QUAL	COND	DIM/NOTE	YB	UNITS	ADJ PRICE	RCNLD



PHOTO	12/11/2012
BLDG COMMENTS	

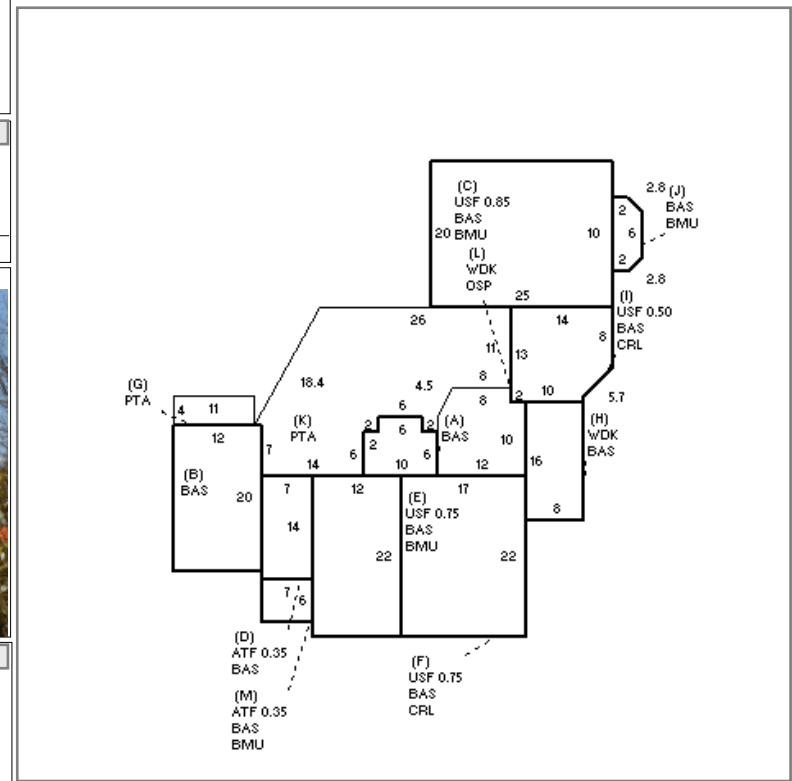

BU
IL
D
ING

BUILDING	CD	ADJ	DESC	MEASURE		
MODEL	1		RESIDENTIAL	LIST		
STYLE	4	1.00	CAPE [100%]	REVIEW	7/8/2019	APK
QUALITY	G	1.55	GOOD [100%]			
FRAME	1	1.00	WOOD FRAME [100%]			

YEAR BLT	1928	SIZE ADJ	1.000	ELEMENT	CD	DESCRIPTION	ADJ	S	BAT	T	DESCRIPTION	UNITS	YB	ADJ PRICE	RCN	TOTAL RCN	1,242,457	
NET AREA	2,962	DETAIL ADJ	1.040	FOUNDATION	4	FLR & WALL	1.00	+	BAS	L	BAS AREA	848	2005	371.99	315,448			
\$NLA(RCN)	\$419	OVERALL	1.000	EXT. COVER	1	WOOD SHINGLE	1.00	+	BMU	N	BSMT UNFINISHED	842		104.97	88,383			
				ROOF SHAPE	1	GABLE	1.00	C	USF	L	UP-STRY FIN	425	2005	315.65	134,149	EXTERIOR	G	
				ROOF COVER	2	WOOD SHIN	1.01	+	BAS	L	BAS AREA	906	1928	371.99	337,023	INTERIOR	V	
				FLOOR COVER	2	SOFTWOOD	1.00	+	ATF	L	FINISHED ATTIC	49	1928	223.77	10,965	KITCHEN	V	
				INT. FINISH	2	DRYWALL	1.00	+	USF	L	UP-STRY FIN	479	1928	315.65	151,195	BATHS	V	
				HEATING/COOL	9	WARM/COOL AIR	1.03	+	CRL	N	CRAWL SPACE	544		31.22	16,983	HEAT	U	
				FUEL SOURCE	2	GAS	1.00	+	PTA	N	PATIO/STOOP	582		27.75	16,148	ELECT	U	
									+	WDK	N	WOOD DECK	264		90.52	23,898		
									I	BAS	L	BAS AREA	170	2002	371.99	63,239		
									I	USF	L	UP-STRY FIN	85	2002	315.65	26,831		
									L	OSP	N	OPEN SCR PORCH	136		122.14	16,611		
										F21	O	FPL 2S 1OP	1		16,082.80	16,083		
										ODS	O	OUT DOOR SHWR-A	1		2,289.40	2,289		

CONDITION ELEM	CD
EXTERIOR	G
INTERIOR	V
KITCHEN	V
BATHS	V
HEAT	U
ELECT	U

EFF.YR/AGE	2018 / 4
COND	4 4 %
FUNC	0
ECON	0
DEPR	4 % GD 96

RCNLD	\$1,192,800
-------	-------------