

Key: 2295

Town of CHATHAM - Fiscal Year 2024

9/7/2023 9:38 am SEQ #: 2.496

LEGAL

LAND

DETACHED

BUILDING

| CURRENT OWNER   |  |  |  | PARCEL ID  |    |            |              | LOCATION         |  |  |  |
|---|--|--|--|------------|----|------------|--------------|------------------|--|--|--|
| HYNES COLIN A<br>6 SMITH LN<br>SOUTHBOROUGH, MA 01772 |  |  |  | 14D-17B-9B |    |            |              | 10 KINGSBURY WAY |  |  |  |
| TRANSFER HISTORY                                      |  |  |  | DOS        | T  | SALE PRICE | BK-PG (Cert) |                  |  |  |  |
| HYNES COLIN A   |  |  |  | 09/29/2017 | QS | 799,000    | 30797-107    |                  |  |  |  |
| SHABAN CHRISTOPHER & GIOR                             |  |  |  | 12/27/2016 | T  | 930,000    | 30193-89     |                  |  |  |  |
| OTTMAR BARBARA  |  |  |  | 04/27/2000 | QS | 250,000    | 12971-183    |                  |  |  |  |

| CLASS  | CLASS%     | DESCRIPTION   |              |        | BN ID      | BN  | CARD   |     |
|--------|------------|---------------|--------------|--------|------------|-----|--------|-----|
| 1010   | 100        | SINGLE FAMILY |              |        |            | 1   | 1 of 1 |     |
| PMT NO | PMT DT     | TY            | DESC         | AMOUNT | INSP       | BY  | 1st    | %   |
| 19-369 | 05/28/2019 | 8             | Cyc. Reinsp. |        | 03/09/2022 | NF  | 100    | 100 |
|        | 10/23/2017 | 98            | INSULATION   | 4,528  | 11/07/2018 | APK | 100    | 100 |
|        | 06/29/2017 | 98            | SALES QUESTI |        |            |     | 0      | 0   |
|        | 02/11/2008 | 50            | Meas & List  |        |            | RRC | 100    | 100 |

| CD  | T | AC/SF/UN | Nbhd | Inf1 | Inf2 | ADJ BASE | SAF | Inf3 | Lpi       | VC   | CREDIT AMT | ADJ VALUE |     |      |  |         |
|-----|---|----------|------|------|------|----------|-----|------|-----------|------|------------|-----------|-----|------|--|---------|
| 100 | S | 5,388    | CH   | 1.00 | 95   | 0.95     | 100 | 1.00 | 1,305,656 | 5.46 | 100        | 1.00      | R10 | 3.75 |  | 881,910 |

| TOTAL | 5,388 SF | ZONING | R20             | FRNT    | 121     | ASSESSED | CURRENT   | PREVIOUS  |
|-------|----------|--------|-----------------|---------|---------|----------|-----------|-----------|
| Nbhd  | CHATHAM  | NOTE   | INF1/ACCESS/LOC |         |         | LAND     | 881,900   | 734,900   |
| Inf1  | 95       |        | BUILDING        | 398,500 | 362,800 |          |           |           |
| Inf2  | 100      |        | DETACHED        | 0       | 0       |          |           |           |
|       |          |        | OTHER           | 0       | 0       |          |           |           |
|       |          |        |                 |         |         | TOTAL    | 1,280,400 | 1,097,700 |

| TY | QUAL | COND | DIM/NOTE | YB | UNITS | ADJ PRICE | RCNLD | PHOTO  | 03/09/2022 |
|----|------|------|----------|----|-------|-----------|-------|--|------------|
|    |      |      |          |    |       |           |       |  |            |

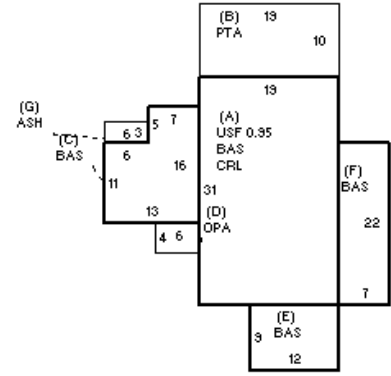

| BUILDING | CD | ADJ  | DESC              | MEASURE | 3/9/2022  | NF  | BLDG COMMENTS     |  |  |  |  |  |  |  |  |  |
|----------|----|------|-------------------|---------|-----------|-----|-------------------|--|--|--|--|--|--|--|--|--|
| MODEL    | 1  |      | RESIDENTIAL       | LIST    | 11/7/2019 | APK | ONLY 1 RM WITH AC |  |  |  |  |  |  |  |  |  |
| STYLE    | 4  | 1.00 | CAPE [100%]       | REVIEW  | 3/28/2022 | EMZ |                   |  |  |  |  |  |  |  |  |  |
| QUALITY  | A  | 1.00 | AVERAGE [100%]    |         |           |     |                   |  |  |  |  |  |  |  |  |  |
| FRAME    | 1  | 1.00 | WOOD FRAME [100%] |         |           |     |                   |  |  |  |  |  |  |  |  |  |

| YEAR BLT   | 1937  | SIZE ADJ   | 1.000        | ELEMENT    | CD  | DESCRIPTION    | ADJ  | S | BAT | T | DESCRIPTION     | UNITS | YB         | ADJ PRICE | RCN     | TOTAL RCN         | 433,130 |  |  |       |           |  |
|------------|-------|------------|--------------|------------|-----|----------------|------|---|-----|---|-----------------|-------|------------|-----------|---------|-------------------|---------|--|--|-------|-----------|--|
| NET AREA   | 1,589 | DETAIL ADJ | 1.050        | FOUNDATION | 3   | FOUND WALL     | 1.00 | A | CRL | N | CRAWL SPACE     | 589   |            | 24.98     | 14,716  | CONDITION ELEM CD |         |  |  |       |           |  |
| \$NLA(RCN) | \$273 | OVERALL    | 1.000        | EXT. COVER | 1   | WOOD SHINGLE   | 1.00 | A | BAS | L | BAS AREA        | 589   | 2000       | 268.52    | 158,157 | EXTERIOR          | G       |  |  |       |           |  |
| CAPACITY   |       |            |              | UNITS      | ADJ | ROOF SHAPE     | 1.00 | A | USF | L | UP-STRY FIN     | 560   | 1937       | 227.85    | 127,594 | INTERIOR          | V       |  |  |       |           |  |
| STORIES    | 1.95  | 1.00       | ROOF COVER   | 1.00       | 1   | ASPH/CMP SHIN  | 1.00 | B | PTA | N | PATIO/STOOP     | 190   |            | 17.90     | 3,401   | KITCHEN           | V       |  |  |       |           |  |
| ROOMS      | 5     | 1.00       | FLOOR COVER  | 1.00       | 2   | SOFTWOOD       | 1.00 | + | BAS | L | BAS AREA        | 440   | 1937       | 268.52    | 118,148 | BATHS             | V       |  |  |       |           |  |
| BEDROOMS   | 3     | 1.00       | INT. FINISH  | 1.00       | 2   | DRYWALL        | 1.00 | D | OPA | N | OPEN PORCH      | 24    |            | 76.08     | 1,826   | HEAT              | U       |  |  |       |           |  |
| FULL BATHS | 2     | 1.00       | HEATING/COOL | 1.05       | 11  | HT-WT/COOL AIR | 1.05 | G | ASH | N | ATT SHED        | 18    |            | 60.61     | 1,091   | ELECT             | U       |  |  |       |           |  |
| 1/2 BATHS  | 1     | 1.00       | FUEL SOURCE  | 1.00       | 2   | GAS            | 1.00 |   | ODS | O | OUT DOOR SHWR-A | 1     |            | 1,477.00  | 1,477   |                   |         |  |  |       |           |  |
| FIXTURES   | 8     | \$6,720    |              |            |     |                |      |   |     |   |                 |       | EFF.YR/AGE | 2014 / 8  |         |                   |         |  |  |       |           |  |
| UNITS      | 1     | 1.00       |              |            |     |                |      |   |     |   |                 |       | COND       | 8 8 %     |         |                   |         |  |  |       |           |  |
|            |       |            |              |            |     |                |      |   |     |   |                 |       |            |           |         |                   |         |  |  | FUNC  | 0         |  |
|            |       |            |              |            |     |                |      |   |     |   |                 |       |            |           |         |                   |         |  |  | ECON  | 0         |  |
|            |       |            |              |            |     |                |      |   |     |   |                 |       |            |           |         |                   |         |  |  | DEPR  | 8 % GD 92 |  |
|            |       |            |              |            |     |                |      |   |     |   |                 |       |            |           |         |                   |         |  |  | RCNLD | \$398,500 |  |