

Key: 2362

Town of CHATHAM - Fiscal Year 2024

9/7/2023 9:38 am SEQ #: 2.563

LEGAL

LAND

DETACHED

BUILDING

CURRENT OWNER				PARCEL ID				LOCATION			
FRANK P & SUSAN M PINTO FAMILY IRR ST 23 ALBA RD WELLESLEY, MA				14E-16-12				171 QUEEN ANNE RD			
TRANSFER HISTORY				DOS	T	SALE PRICE	BK-PG (Cert)				
FRANK P & SUSAN M PINTO F				01/07/2021	A	1 (225010)					
PINTO FRANK & SUSAN				09/15/2009	QS	867,500	24033-71				
RUTH L COOLING REV TRUST				07/07/1992	A	1 ()					

CLASS	CLASS%	DESCRIPTION			BN ID	BN	CARD	
1010	100	SINGLE FAMILY				1	1 of 1	
PMT NO	PMT DT	TY	DESC	AMOUNT	INSP	BY	1st	%
21-971	10/22/2021	2	Additions	6,000	03/25/2022	NF	100	100
19-0625	09/16/2019	99	n/a		01/29/2020	NF	100	100
19-486	07/02/2019	13	SH.MTL/FHAIR	28,500	01/29/2020	NF	100	100
18-1027	12/11/2018	1	New Construc	800,000	01/29/2020	NF	100	100
18-1017	12/05/2018	5	Demolitions	5,000	02/06/2019	TCK	100	100

CD	T	AC/SF/UN	Nbhd	Inf1	Inf2	ADJ BASE	SAF	Inf3	Lpi	VC	CREDIT AMT	ADJ VALUE
100	S	13,566	CH	1.00	75 0.75 100 1.00	1,319,400	2.47	100 1.00	PV1	4.80		1,013,960

TOTAL	13,566 SF	ZONING	R40	FRNT	79	ASSESSED	CURRENT	PREVIOUS
Nbhd	CHATHAM	NOTE Inf1=access easment / lawsuit	LAND	1,014,000	844,900			
Inf1	75		BUILDING	2,394,300	2,062,300			
Inf2	100		DETACHED	0	0			
			OTHER	0	0			
TOTAL			3,408,300	2,907,200				

TY	QUAL	COND	DIM/NOTE	YB	UNITS	ADJ PRICE	RCNLD



BLDG COMMENTS	LLF=1RM,1FBTH
---------------	---------------

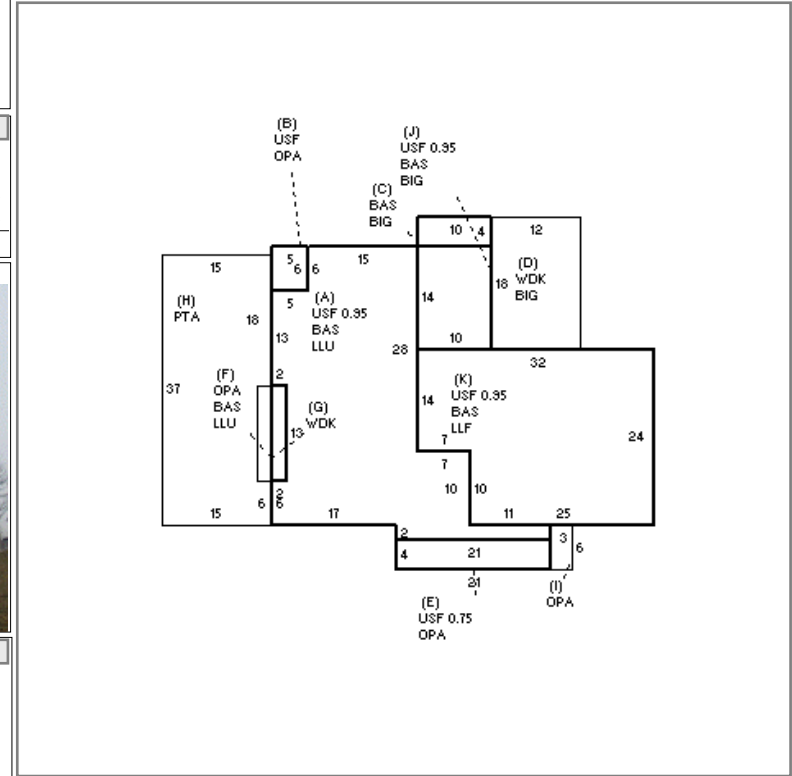

BUILDING	CD	ADJ	DESC	MEASURE	1/29/2020	NF
MODEL	1		RESIDENTIAL	LIST	1/29/2020	EST
STYLE	5	1.00	COLONIAL [100%]	REVIEW	4/6/2022	EMZ
QUALITY	V	2.35	VERY GOOD [100%]			
FRAME	1	1.00	WOOD FRAME [100%]			

YEAR BLT	2018	SIZE ADJ	1.000	ELEMENT	CD	DESCRIPTION	ADJ	S	BAT	T	DESCRIPTION	UNITS	YB	ADJ PRICE	RCN	TOTAL RCN	2,443,204		
NET AREA	3,384	DETAIL ADJ	1.040	FOUNDATION	4	FLR & WALL	1.00	+	LLU	N	LOWER LEVEL UN	842		301.80	254,113	CONDITION ELEM	CD		
\$NLA(RCN)	\$722	OVERALL	1.000	EXT. COVER	1	WOOD SHINGLE	1.00	+	BAS	L	BAS AREA	1,720	2018	535.63	921,287	EXTERIOR	A		
				ROOF SHAPE	3	GAMBREL	1.00	+	USF	L	UP-STRY FIN	1,664	2018	454.50	756,289	INTERIOR	G		
				ROOF COVER	2	WOOD SHIN	1.01	+	OPA	N	OPEN PORCH	158		178.84	28,256	KITCHEN	A		
				FLOOR COVER	1	HARDWOOD	1.00	+	BIG	N	BUILT-IN GARAGE	396		189.32	74,972	BATHS	A		
				INT. FINISH	2	DRYWALL	1.00	+	WDK	N	WOOD DECK	242		137.24	33,213	HEAT	A		
				HEATING/COOL	9	WARM/COOL AIR	1.03	H	PTA	N	PATIO/STOOP	529		42.06	22,252	ELECT	A		
				FUEL SOURCE	2	GAS	1.00	K	LLF	N	LOWER LEVEL FIN	698		394.18	275,140				
									GFP	O	GAS LOG/FP/E FP	2		14,620.55	29,241				
									ODS	O	OUT DOOR SHWR-A	1		3,471.00	3,471				
																	EFF.YR/AGE	2020 / 2	
																	COND	2 2 %	
																	FUNC	0	
																	ECON	0	
																	DEPR	2 % GD 98	
																	RCNLD	\$2,394,300	