

Key: 2494

Town of CHATHAM - Fiscal Year 2024

9/7/2023 9:38 am SEQ #: 2.700

LEGALS

CURRENT OWNER		PARCEL ID		LOCATION	
CARR MICHAEL J & PATRICIA L PO BOX 456 NEW CASTLE, NH 03854-0456		14F-5-E2		105 HITCHING POST RD	
TRANSFER HISTORY		DOS	T	SALE PRICE	BK-PG (Cert)
CARR MICHAEL J & PATRICIA		11/05/2010	QS	750,000	(192869)
RYDER JOHN D & GLENNA L		07/29/1997	99	105,000	(145289)
DEVLIN		10/08/1993	QS	75,000	(131648)

CLASS	CLASS%	DESCRIPTION		BN ID	BN	CARD			
1010	100	SINGLE FAMILY			1	1 of 1			
PMT NO	PMT DT	TY	DESC	AMOUNT	INSP	BY	1st	%	
23-648	08/03/2023	10	Reroof	18,150				0	0
00-302	02/12/2008	50	Meas & List			RRC	100	100	
97-448	07/01/2000	2	Additions	800			100	100	
1997272	12/01/1997	1	New Construc	200,000			100	100	
	11/19/1997	99	n/a				100	100	

LAND

CD	T	AC/SF/UN	Nbhd	Inf1	Inf2	ADJ BASE	SAF	Inf3	Lpi	VC	CREDIT AMT	ADJ VALUE
100	S	15,310	CH	1.00	100	1.00	100	1.00	R06	2.50		716,910

TOTAL	15,310 SF	ZONING	R20	FRNT	106	ASSESSED	CURRENT	PREVIOUS
Nbhd	CHATHAM	NOTE				LAND	716,900	597,400
Inf1	100		BUILDING	741,800	675,000			
Inf2	100		DETACHED	0	0			
			OTHER	0	0			
						TOTAL	1,458,700	1,272,400

DETACHED

TY	QUAL	COND	DIM/NOTE	YB	UNITS	ADJ PRICE	RCNLD	PHOTO	01/04/2013
									

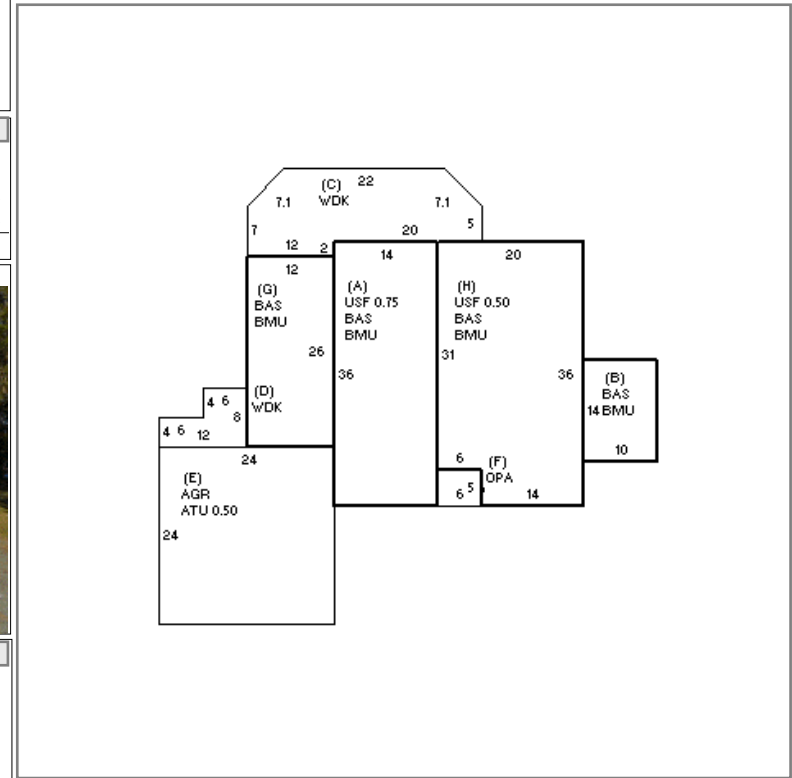

BUILDING

BUILDING	CD	ADJ	DESC	MEASURE	LIST	REVIEW	1/23/2013	MR
MODEL	1		RESIDENTIAL					
STYLE	4	1.00	CAPE [100%]					
QUALITY	+	1.20	PLUS AVE [100%]					
FRAME	1	1.00	WOOD FRAME [100%]					

YEAR BLT	1998	SIZE ADJ	1.000	ELEMENT	CD	DESCRIPTION	ADJ	S	BAT	T	DESCRIPTION	UNITS	YB	ADJ PRICE	RCN	TOTAL RCN	938,968
NET AREA	2,369	DETAIL ADJ	1.050	FOUNDATION	4	FLR & WALL	1.00	+	BMU	N	BSMT UNFINISHED	1,646		79.01	130,050		
\$NLA(RCN)	\$396	OVERALL	1.000	EXT. COVER	1	WOOD SHINGLE	1.00	+	BAS	L	BAS AREA	1,646	1998	299.98	493,762		
				ROOF SHAPE	1	GABLE	1.00	+	USF	L	UP-STRY FIN	723	1998	254.54	184,032		
				ROOF COVER	1	ASPH/CMP SHIN	1.00	+	WDK	N	WOOD DECK	391		70.08	27,401		
				FLOOR COVER	14	HARDWD/ASPH TL	1.00	E	ATU	N	UNFIN ATTIC	288		94.20	27,130		
				INT. FINISH	2	DRYWALL	1.00	E	AGR	N	ATTACHED GARAGE	576		92.60	53,339		
				HEATING/COOL	11	HT-WT/COOL AIR	1.05	F	OPR	N	OPEN PORCH	30		91.32	2,740		
				FUEL SOURCE	2	GAS	1.00		F21	O	FPL 2S 1OP	1		12,451.20	12,451		

CONDITION ELEM	CD
EXTERIOR	
INTERIOR	
KITCHEN	
BATHS	
HEAT	
ELECT	

EFF.YR/AGE	2000 / 22
COND	21 21%
FUNC	0
ECON	0
DEPR	21 % GD 79
RCNLD	\$741,800