

Key: 2609

Town of CHATHAM - Fiscal Year 2024

9/7/2023 9:38 am SEQ #: 2.816

LEG  
AL  
LAND

CURRENT OWNER				PARCEL ID				LOCATION				
CONROY LINDA S 51 COD LN CHATHAM, MA 02633				14G-64-B89				51 COD LN				
TRANSFER HISTORY				DOS	T	SALE PRICE	BK-PG (Cert)					
CONROY LINDA S				04/28/2014	QS	465,000	28109-223					
DALY SCOTT M & CHARNA M				03/17/2010	H	292,000	24423-119					
ESTATE OF CATHERINE E DIE				08/08/2006	A	1	21252-102					
CD	T	AC/SF/UN	Nbhd	Inf1	Inf2	ADJ BASE	SAF	Inf3	Lpi	VC	CREDIT AMT	ADJ VALUE
100	S	10,100	MC	1.00	100	1.00	100	1.00	R06	1.20		323,880

CLASS	CLASS%	DESCRIPTION			BN ID	BN	CARD	
1010	100	SINGLE FAMILY				1	1 of 1	
PMT NO	PMT DT	TY	DESC	AMOUNT	INSP	BY	1st	%
12-591	11/23/2015	3	Renovations	6,000	11/23/2015	APK	100	100
	12/19/2012	3	Renovations		05/14/2015	MW	100	100
	01/24/2011	50	Meas & List			RRC	100	100
10-172	05/19/2010	10	Reroof	3,000	01/24/2011	JB	100	100
	02/18/2003	50	Meas & List				100	100

LAND

TOTAL	10,100 SF	ZONING	R40	FRNT	96	ASSESSED	CURRENT	PREVIOUS
Nbhd	MID CHATHAM	NOTE				LAND	323,900	269,900
Inf1	100		BUILDING	358,300	330,100			
Inf2	100		DETACHED	0	0			
			OTHER	0	0			
						<b>TOTAL</b>	<b>682,200</b>	<b>600,000</b>

DETACHED

TY	QUAL	COND	DIM/NOTE	YB	UNITS	ADJ PRICE	RCNLD	PHOTO	10/19/2021
									

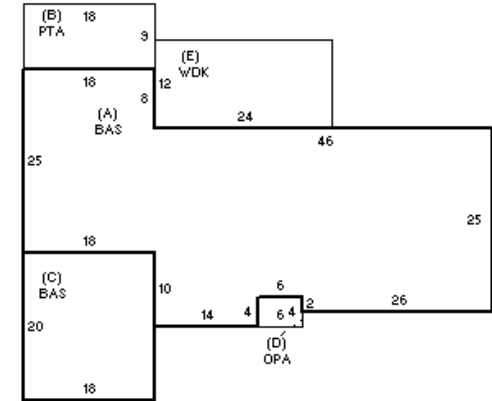

BUILDING

BUILDING	CD	ADJ	DESC	MEASURE	10/19/2021	NF
MODEL	1		RESIDENTIAL	LIST	10/19/2021	EST
STYLE	1	0.85	RANCH [100%]	REVIEW	12/1/2021	EMZ
QUALITY	A	1.00	AVERAGE [100%]			
FRAME	1	1.00	WOOD FRAME [100%]			

BLDG COMMENTS		

BUILDING

YEAR BLT	1966	SIZE ADJ	1.000	ELEMENT	CD	DESCRIPTION	ADJ	S	BAT	T	DESCRIPTION	UNITS	YB	ADJ PRICE	RCN	TOTAL RCN	426,570														
NET AREA	1,976	DETAIL ADJ	0.807	FOUNDATION	2	SLAB	0.95	A	BAS	L	BAS AREA	1,616	1966	197.83	319,688																
\$NLA(RCN)	\$216	OVERALL	1.000	EXT. COVER	1	WOOD SHINGLE	1.00	B	PTA	N	PATIO/STOOP	162		17.90	2,900																
				ROOF SHAPE	1	GABLE	1.00	C	BAS	L	BAS AREA	360	2012	197.83	71,218																
				ROOF COVER	1	ASPH/CMP SHIN	1.00	D	OPA	N	OPEN PORCH	24		76.08	1,826																
				FLOOR COVER	1	HARDWOOD	1.00	E	WDK	N	WOOD DECK	288		58.40	16,819																
				INT. FINISH	2	DRYWALL	1.00		F11	O	FPL 1S 1OP	1		7,477.00	7,477																
				HEATING/COOL	2	HOT WATER	1.00		ODS	O	OUT DOOR SHWR-A	1		1,477.00	1,477																
				FUEL SOURCE	2	GAS	1.00																								
<table border="1"> <thead> <tr> <th>CONDITION ELEM</th> <th>CD</th> </tr> </thead> <tbody> <tr> <td>EXTERIOR</td> <td>A</td> </tr> <tr> <td>INTERIOR</td> <td>G</td> </tr> <tr> <td>KITCHEN</td> <td>V</td> </tr> <tr> <td>BATHS</td> <td>V</td> </tr> <tr> <td>HEAT</td> <td>A</td> </tr> <tr> <td>ELECT</td> <td>U</td> </tr> </tbody> </table>																	CONDITION ELEM	CD	EXTERIOR	A	INTERIOR	G	KITCHEN	V	BATHS	V	HEAT	A	ELECT	U	
CONDITION ELEM	CD																														
EXTERIOR	A																														
INTERIOR	G																														
KITCHEN	V																														
BATHS	V																														
HEAT	A																														
ELECT	U																														
<table border="1"> <thead> <tr> <th>EFF. YR/AGE</th> <td colspan="2">2006 / 16</td> </tr> </thead> <tbody> <tr> <td>COND</td> <td>16</td> <td>16 %</td> </tr> <tr> <td>FUNC</td> <td>0</td> <td></td> </tr> <tr> <td>ECON</td> <td>0</td> <td></td> </tr> <tr> <td>DEPR</td> <td>16</td> <td>% GD 84</td> </tr> </tbody> </table>																	EFF. YR/AGE	2006 / 16		COND	16	16 %	FUNC	0		ECON	0		DEPR	16	% GD 84
EFF. YR/AGE	2006 / 16																														
COND	16	16 %																													
FUNC	0																														
ECON	0																														
DEPR	16	% GD 84																													
RCNLD																\$358,300															