

Key: 3006

Town of CHATHAM - Fiscal Year 2024

9/7/2023 9:38 am SEQ #: 3.253

LEGAL

CURRENT OWNER				PARCEL ID				LOCATION			
TOWN OF CHATHAM ELDREDGE PUBLIC LIBRARY 564 MAIN ST CHATHAM, MA 02633				15D-0-105				564 MAIN ST			
TRANSFER HISTORY				DOS	T	SALE PRICE		BK-PG (Cert)			
TOWN OF CHATHAM				01/07/1991	E			7406-97			

CLASS	CLASS%	DESCRIPTION			BN ID	BN	CARD	
9560	100	LIBRARIES, MUSEUMS				1	1 of 1	
PMT NO	PMT DT	TY	DESC	AMOUNT	INSP	BY	1st	%
22-457	01/13/2023	71	ABC				100	100
	05/31/2022	11	Window Rplc	497,000			0	0
	01/28/2022	71	ABC				100	100
21-317	03/30/2021	10	Reroof	314,200			0	0
	01/08/2020	71	ABC				100	100

LAND

CD	T	AC/SF/UN	Nbhd	Inf1	Inf2	ADJ BASE	SAF	Inf3	Lpi	VC	CREDIT AMT	ADJ VALUE
103	S	22,200	CI	1.00	100	1,709,290	1.58	100	1.00	MS8	4.10	1,374,030

TOTAL	22,200 SF	ZONING	M	FRNT	80	ASSESSED	CURRENT	PREVIOUS
Nbhd	COMMERCIAL	NOTE				LAND	1,374,000	1,127,300
Inf1	100		BUILDING	3,570,500	2,967,700			
Inf2	100		DETACHED	22,000	23,400			
			OTHER	0	0			
						TOTAL	4,966,500	4,118,400

DETACHED

TY	QUAL	COND	DIM/NOTE	YB	UNITS	ADJ PRICE	RCNLD
LH1	A	1.00	50 0.50		3	2,291.80	3,400
SN5	G	1.20	20 0.80 3X8		24	137.04	2,600
S/V	A	1.00	20 0.80 STN MONUMENT		20,000	1.00	16,000



BUILDING

BUILDING	CD	ADJ	DESC	MEASURE		
MODEL	5		CIM	LIST		
STYLE	93	1.76	LIBRARY [100%]	REVIEW	6/5/2019	TD
QUALITY	E	2.00	EXCELLENT [100%]			
FRAME	2	1.00	MASONRY [100%]			

BLDG COMMENTS

PUBLIC LIBRARY

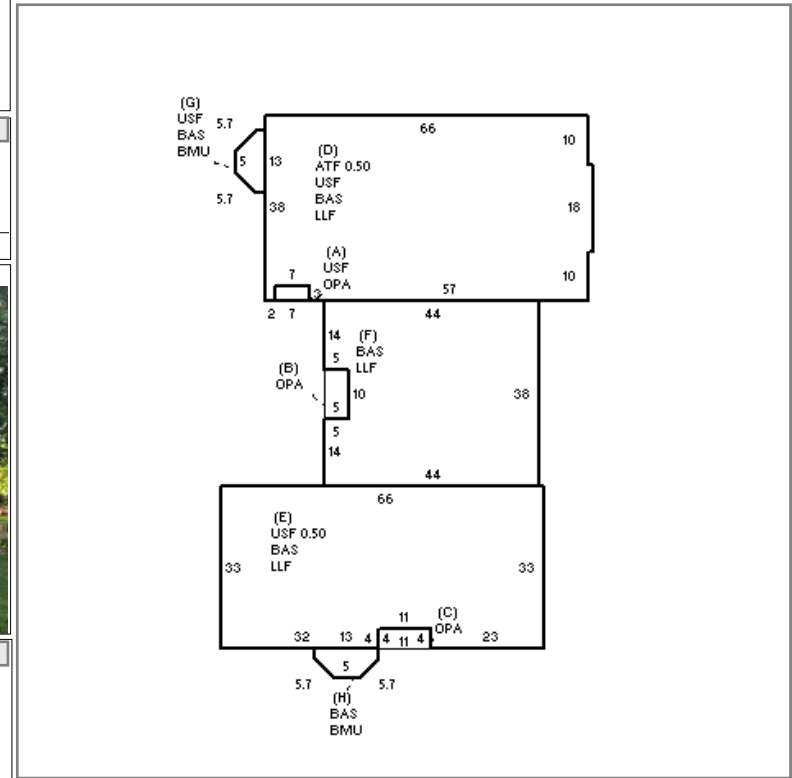

G

YEAR BLT	1895	SIZE ADJ	1.000	ELEMENT	CD	DESCRIPTION	ADJ	S	BAT	T	DESCRIPTION	UNITS	YB	ADJ PRICE	RCN	TOTAL RCN	5,174,569
NET AREA	17,554	DETAIL ADJ	2.195	FOUNDATION	4	FLR & WALL	1.00	+	OPA	N	OPEN PORCH	115		49.28	5,667		
\$NLA(RCN)	\$295	OVERALL	1.100	EXT. COVER	12	BRICK VEENEER	1.05	+	USF	L	UP-STRY FIN	1,150	1895	323.45	371,969		
				ROOF SHAPE	1	GABLE	1.00	D	LLF	L	LOW-LEV FIN	2,505	1968	275.91	691,149	EXTERIOR	G
				ROOF COVER	5	SLATE	1.02	D	BAS	L	BASE AREA	2,505	1968	323.45	810,246	INTERIOR	A
				FLOOR COVER	3	W/W CARPET	1.00	D	USF	L	UP-STRY FIN	2,505	1968	323.45	810,246	CDN/APP	A
				INT. FINISH	12	PLASTR/DRYWLI	1.00	D	ATF	L	ATTIC FINISHED	1,253	1895	72.08	90,318		
				HEATING/COOL	11	HOT WT/COOL AIR	1.02	E	LLF	L	LOW-LEV FIN	2,134	1895	275.91	588,787		
				FUEL SOURCE	1	OIL	1.00	+	BAS	L	BASE AREA	3,880	1895	323.45	1,254,991		
								F	LLF	L	LOW-LEV FIN	1,622	1895	275.91	447,523		
								+	BMU	N	BSMT UNF	124		31.13	3,860		
									MZP	N	PART MEZ	460		32.56	14,978		
									SPW	N	SPRKN-WET	8,929		1.43	12,769		
									ELP	O	PASSGR. ELEV.	1		66,160.60	66,161		
									F21	O	FPL 2S 1OP	1		5,907.00	5,907		

CONDITION ELEM	CD	
EXTERIOR		G
INTERIOR		A
CDN/APP		A
EFF.YR/AGE	1982 / 40	
COND	31	31 %
FUNC	0	
ECON	0	
DEPR	31	% GD 69
RCNLD	\$3,570,500	