

Key: 3151

Town of CHATHAM - Fiscal Year 2024

9/7/2023 9:38 am SEQ #: 3.413

LEGALS

DETACHED

BUILDING

Table with columns: CURRENT OWNER, PARCEL ID, LOCATION, TRANSFER HISTORY, DOS, T, SALE PRICE, BK-PG (Certs). Includes owner info for SLOAN EDESSE & SLOAN JULIAN R III and transfer history from 2012.

Table with columns: CD, T, AC/SF/UN, Nbhd, Infil1, Infil2, ADJ BASE, SAF, Infil3, Lpi, VC, CREDIT AMT, ADJ VALUE. Includes zoning (R20) and assessed values.

Table with columns: TY, QUAL, COND, DIM/NOTE, YB, UNITS, ADJ PRICE, RCNLD. Includes building quality metrics and a photo of the house.

Table with columns: BUILDING, CD, ADJ, DESC, MEASURE, 2/23/2022, NF, LIST, 2/23/2022, EST, REVIEW, 3/9/2022, EMZ. Includes building details like model, style, and quality.

Table with columns: YEAR BLT, SIZE ADJ, NET AREA, \$NLA(RCN), CAPACITY, UNITS, ADJ. Includes capacity and unit counts for various building features.

Table with columns: ELEMENT, CD, DESCRIPTION, ADJ. Lists building elements like foundation, roof, and floor cover with their respective adjustment factors.

Table with columns: S, BAT, T, DESCRIPTION, UNITS, YB, ADJ PRICE, RCN. Lists building systems like LLU, BAS, EPA, WDK, CRL, USF, F21 with their costs and RCNs.

Summary table with columns: TOTAL RCN, CONDITION ELEM, CD, EFF.YR/AGE, COND, FUNC, ECON, DEPR, RCNLD. Includes total RCN (703.064) and depreciation details.

Table with columns: CLASS, CLASS%, DESCRIPTION, BN ID, BN, CARD. Includes payment history for 1010 and 100 classes.

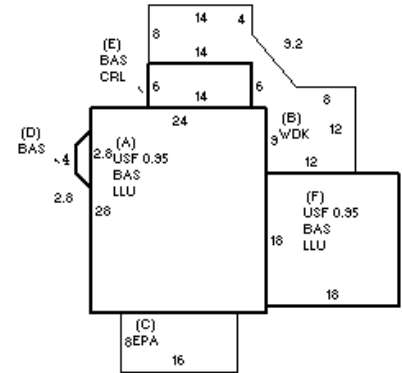

BLDG COMMENTS