

Key: 3189

Town of CHATHAM - Fiscal Year 2024

9/7/2023 9:38 am SEQ #: 3.458

LEGALS AND

Table with columns: CURRENT OWNER, PARCEL ID, LOCATION, TRANSFER HISTORY, DOS, T, SALE PRICE, BK-PG (Cert). Includes owner LYNCH STEVEN M and parcel 15E-53-50.

Table with columns: CLASS, CLASS%, DESCRIPTION, BN ID, BN, CARD. Includes details for SINGLE FAMILY class and various PMT NO entries.

Table with columns: CD, T, AC/SF/UN, Nbhd, Inf1, Inf2, ADJ BASE, SAF, Inf3, Lpi, VC, CREDIT AMT, ADJ VALUE. Includes totals for assessed, current, and previous values.

Table with columns: TY, QUAL, COND, DIM/NOTE, YB, UNITS, ADJ PRICE, RCNLD. Includes details for SHF (Single Family Home) type.

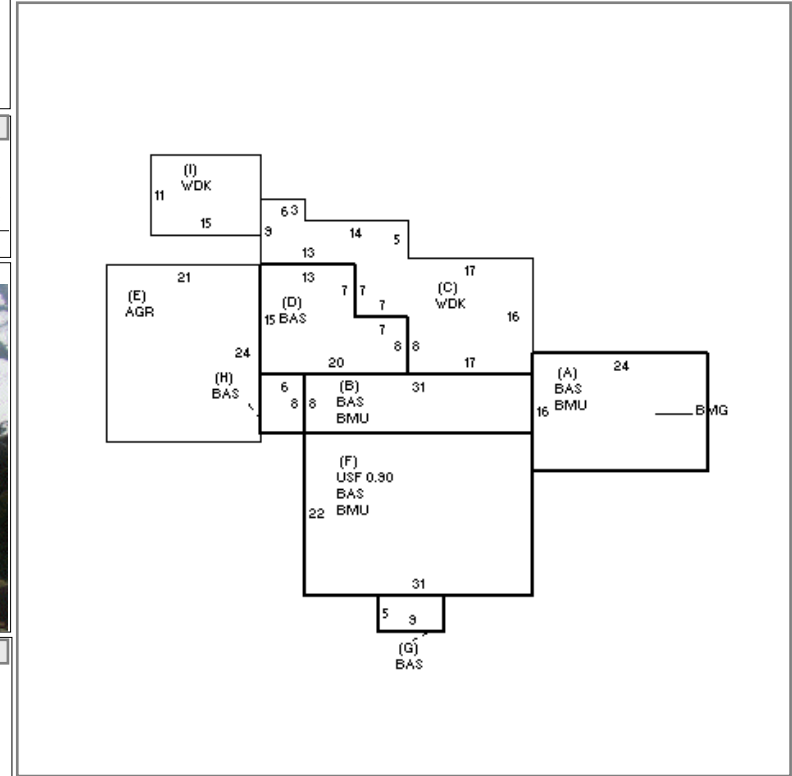

Table with columns: BUILDING, CD, ADJ, DESC, MEASURE, 2/23/2022, NF. Includes details for residential building quality and frame.

Table with columns: BLDG COMMENTS. Currently empty.

DETACHED

BUILDING

Large table with columns: YEAR BLT, SIZE ADJ, ELEMENT, CD, DESCRIPTION, ADJ, S, BAT, T, DESCRIPTION, UNITS, YB, ADJ PRICE, RCN, TOTAL RCN, CONDITION ELEM, CD. Includes detailed building specifications and a summary of RCN values.