

Key: 3224

Town of CHATHAM - Fiscal Year 2024

9/7/2023 9:38 am SEQ #: 3.499

LEGAL

LAND

DETACHED

BUILDING

CURRENT OWNER				PARCEL ID				LOCATION			
LKSA TRUST COOK SYDNEY TRUSTEE 567 MAIN ST HINGHAM, MA 02043-3126				15F-11-G1				255 OLD HARBOR RD			
TRANSFER HISTORY				DOS	T	SALE PRICE	BK-PG (Cert)				
LKSA TRUST				04/29/2019	O	850,000	31982-65				
FLETCHER WARREN L & BETH				06/01/1973	O	32,000	1836-176				

CLASS	CLASS%	DESCRIPTION			BN ID	BN	CARD	
1010	100	SINGLE FAMILY				1	1 of 1	
PMT NO	PMT DT	TY	DESC	AMOUNT	INSP	BY	1st	%
22-509	06/09/2022	3	Renovations	50,000	02/16/2023	NF	100	100
20-0549	09/15/2020	2	Additions	41,000	04/07/2022	NF	100	100
20-070	01/30/2020	3	Renovations	22,700	04/02/2021	NF	100	100
	08/07/2019	98	SALES QUESTI				100	100
	11/06/2015	20	Splits/Land		11/06/2015	APK	100	100

CD	T	AC/SF/UN	Nbhd	Inf1	Inf2	ADJ BASE	SAF	Inf3	Lpi	VC	CREDIT AMT	ADJ VALUE
100	S	15,404	CH	1.00	100	1.00	100	1.00	MR1	2.50		717,590

TOTAL	15,404 SF	ZONING	R20	FRNT	100	ASSESSED	CURRENT	PREVIOUS
Nbhd	CHATHAM	NOTE FY17 CHANGE SQ FT 15404 PER PLNBK 214/45 LOT D	LAND	717,600	478,400			
Inf1	100		BUILDING	894,300	789,000			
Inf2	100		DETACHED	14,000	13,400			
			OTHER	0	0			
		TOTAL		1,625,900	1,280,800			

TY	QUAL	COND	DIM/NOTE	YB	UNITS	ADJ PRICE	RCNLD
FBN	A	1.00	30 0.70	1988	560	32.76	12,800
SHF	A	1.00	10 0.90	2000	96	14.26	1,200



BLDG COMMENTS
MST=FLU PIPES
23 SOLAR PANELS
.5BBATH=BMF

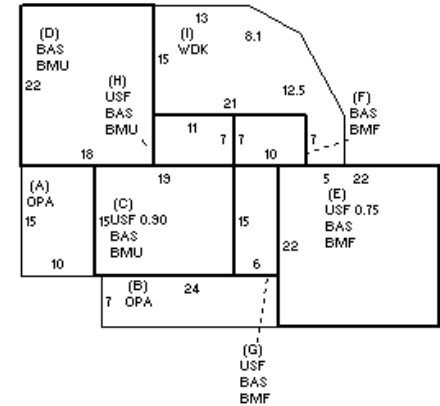

BUILDING	CD	ADJ	DESC	MEASURE
MODEL	1		RESIDENTIAL	
STYLE	18	1.30	RENO'D ANTIQUE [100%]	LIST
QUALITY	+	1.20	PLUS AVE [100%]	REVIEW
FRAME	1	1.00	WOOD FRAME [100%]	3/15/2023 EMZ

YEAR BLT	1820	SIZE ADJ	1.000	ELEMENT	CD	DESCRIPTION	ADJ	S	BAT	T	DESCRIPTION	UNITS	YB	ADJ PRICE	RCN	TOTAL RCN	1,052,143			
NET AREA	2,189	DETAIL ADJ	1.365	FOUNDATION	4	FLR & WALL	1.00	+	OPA	N	OPEN PORCH	318		91.32	29,040	CONDITION ELEM	CD			
\$NLA(RCN)	\$481	OVERALL	1.000	EXT. COVER	4	VINYL	1.00	+	BMU	N	BSMT UNFINISHED	758		93.29	70,715	EXTERIOR	V			
				ROOF SHAPE	1	GABLE	1.00	+	BAS	L	BAS AREA	1,402	1820	394.51	553,109	INTERIOR	G			
				ROOF COVER	1	ASPH/CMP SHIN	1.00	+	USF	L	UP-STRY FIN	710	1820	334.76	237,678	KITCHEN	G			
				FLOOR COVER	2	SOFTWOOD	1.00	+	BMF	N	BSMT FINISH-SEP	644		130.32	83,926	BATHS	G			
				INT. FINISH	12	PLASTR/DRYWLI	1.00	H	USF	L	UP-STRY FIN	77	2020	334.75	25,776	HEAT	U			
				HEATING/COOL	11	HT-WT/COOL AIR	1.05	I	WDK	N	WOOD DECK	354		70.08	24,809	ELECT	U			
				FUEL SOURCE	2	GAS	1.00		PTA	N	PATIO/STOOP	112		21.48	2,406					
													GFP	O	GAS LOG/FP/E FP	1	7,466.40	7,466		
													MST	O	MASONRY STACK	2	2,481.60	4,963		
													ODS	O	OUT DOOR SHWR-A	1	1,772.40	1,772		
													EFF.YR/AGE		2007 / 15					
													COND	15	15%					
													FUNC	0						
													ECON	0						
													DEPR	15	% GD	85				
													RCNLD				\$894,300			