

Key: 3351

Town of CHATHAM - Fiscal Year 2024

9/7/2023 9:38 am SEQ #: 3.640

LEGAL

LAND

DETACHED

BUILDING

| CURRENT OWNER | | | | PARCEL ID | | | | LOCATION | | | |
|---|--|--|--|------------|----|------------|--------------|----------------|--|--|--|
| CHIEF MENEKISH REALTY TRUST BRIGHAM MARILYN P & PAUL L TRSTES 10 PARK ST NORTHBOROUGH, MA 01532-2614 | | | | 15G-67-M2 | | | | 17 MENEKISH LN | | | |
| TRANSFER HISTORY | | | | DOS | T | SALE PRICE | BK-PG (Cert) | | | | |
| CHIEF MENEKISH REALTY TRU | | | | 05/17/2004 | N | 250,000 | 18600-327 | | | | |
| POND VIRGINIA | | | | 12/16/1983 | QS | 45,000 | 3961-16 | | | | |

| CLASS | CLASS% | DESCRIPTION | | | BN ID | BN | CARD | |
|---------------------|------------|---------------|-------------|--------|-------|-----|--------|-----|
| 1010 | 100 | SINGLE FAMILY | | | | 1 | 1 of 1 | |
| PMT NO | PMT DT | TY | DESC | AMOUNT | INSP | BY | 1st | % |
| P2002267 1983226 | 05/13/2008 | 50 | Meas & List | | | RRC | 100 | 100 |
| | 03/02/2003 | 50 | Meas & List | | | JB | 100 | 100 |
| | 06/13/2002 | 10 | Reroof | | | | 100 | 100 |
| | 12/21/1983 | 99 | n/a | | | | 100 | 100 |

| CD | T | AC/SF/UN | Nbhd | Inf1 | Inf2 | ADJ BASE | SAF | Inf3 | Lpi | VC | CREDIT AMT | ADJ VALUE | | | | |
|-----|---|----------|------|------|------|----------|-----|------|---------|------|------------|-----------|-----|------|--|---------|
| 100 | S | 18,712 | NC | 1.00 | 90 | 0.90 | 100 | 1.00 | 659,700 | 1.88 | 100 | 1.00 | R08 | 2.00 | | 532,260 |

| TOTAL | 18,712 SF | ZONING | R40 | FRNT | 125 | ASSESSED | CURRENT | PREVIOUS |
|-------|---------------|--------|----------|-----------|-----------|----------|---------|----------|
| Nbhd | NORTH CHATHAM | NOTE | LAND | 532,300 | 510,100 | | | |
| Inf1 | 90 | | BUILDING | 568,800 | 554,500 | | | |
| Inf2 | 100 | | DETACHED | 19,200 | 18,300 | | | |
| | | | OTHER | 0 | 0 | | | |
| TOTAL | | | | 1,120,300 | 1,082,900 | | | |

| TY | QUAL | COND | DIM/NOTE | YB | UNITS | ADJ PRICE | RCNLD | PHOTO |
|-----|------|------|---------------|------|-------|-----------|--------|------------|
| DGF | A | 1.00 | 10 0.90 20X24 | 1985 | 480 | 44.54 | 19,200 | 01/04/2013 |



| BUILDING | CD | ADJ | DESC | MEASURE | REVIEW | DATE | MR |
|----------|----|------|-------------------|---------|-----------|------|----|
| MODEL | 1 | | RESIDENTIAL | LIST | | | |
| STYLE | 5 | 1.00 | COLONIAL [100%] | | | | |
| QUALITY | + | 1.20 | PLUS AVE [100%] | | | | |
| FRAME | 1 | 1.00 | WOOD FRAME [100%] | | 1/15/2013 | | MR |

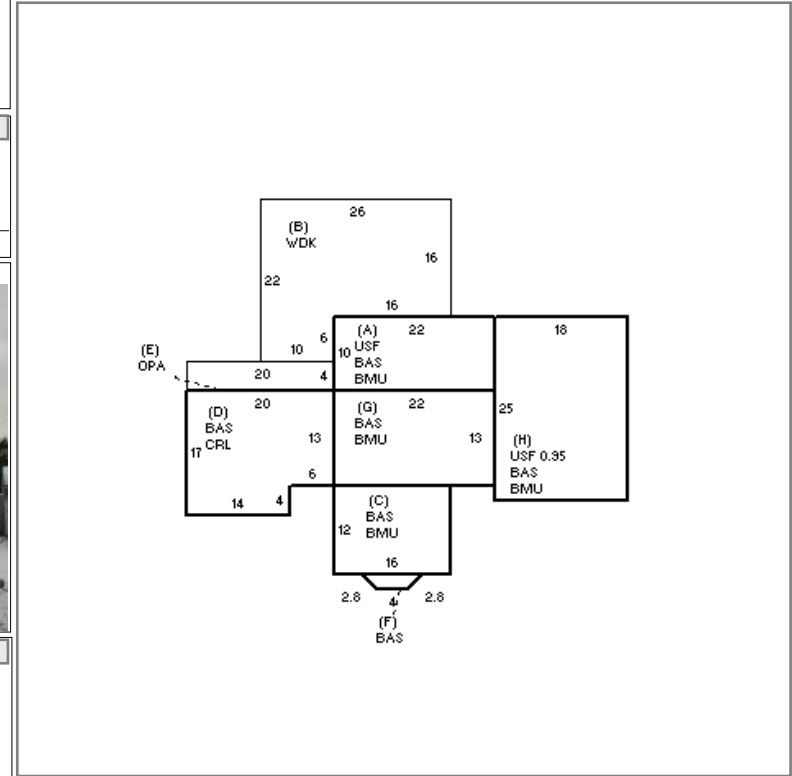

| YEAR BLT | 1984 | SIZE ADJ | 1.000 | ELEMENT | CD | DESCRIPTION | ADJ | S | BAT | T | DESCRIPTION | UNITS | YB | ADJ PRICE | RCN | TOTAL RCN | 748,409 | |
|------------|-------|------------|--------------|------------|---------------|--------------|-------|------|-----|-------------|-----------------|-----------|-----------|-----------|---------|----------------|-----------|---------|
| NET AREA | 2,124 | DETAIL ADJ | 1.000 | FOUNDATION | 4 | FLR & WALL | 1.00 | + | BMU | N | BSMT UNFINISHED | 1,148 | | 80.51 | 92,429 | CONDITION ELEM | CD | |
| \$NLA(RCN) | \$352 | OVERALL | 1.000 | EXT. COVER | 1 | WOOD SHINGLE | 1.00 | + | USF | L | UP-STRY FIN | 648 | 1984 | 246.53 | 159,750 | EXTERIOR | A | |
| CAPACITY | | | UNITS | ADJ | ROOF SHAPE | 1 | GABLE | 1.00 | B | WDK | N | WOOD DECK | 476 | 70.08 | 33,358 | INTERIOR | G | |
| STORIES | 1.95 | 1.00 | ROOF COVER | 1 | ASPH/CMP SHIN | 1.00 | D | CRL | N | CRAWL SPACE | 316 | | 23.95 | 7,567 | KITCHEN | A | | |
| ROOMS | 7 | 1.00 | FLOOR COVER | 32 | CARPET/SOFTWD | 1.00 | D | BAS | L | BAS AREA | 316 | 1986 | 290.53 | 91,808 | BATHS | A | | |
| BEDROOMS | 3 | 1.00 | INT. FINISH | 2 | DRYWALL | 1.00 | E | OPA | N | OPEN PORCH | 80 | | 91.32 | 7,306 | HEAT | A | | |
| FULL BATHS | 2 | 1.00 | HEATING/COOL | 2 | HOT WATER | 1.00 | + | BAS | L | BAS AREA | 1,160 | 1984 | 290.53 | 337,020 | ELECT | A | | |
| 1/2 BATHS | 0 | 1.00 | FUEL SOURCE | 1 | OIL | 1.00 | | F21 | O | FPL 2S 1OP | 1 | | 12,451.20 | 12,451 | | | | |
| FIXTURES | 7 | \$6,720 | | | | | | | | | | | | | | | | |
| UNITS | 1 | 1.00 | | | | | | | | | | | | | | | | |
| | | | | | | | | | | | | | | | | EFF.YR/AGE | 1991 / 31 | |
| | | | | | | | | | | | | | | | | COND | 24 | 24 % |
| | | | | | | | | | | | | | | | | FUNC | 0 | |
| | | | | | | | | | | | | | | | | ECON | 0 | |
| | | | | | | | | | | | | | | | | DEPR | 24 | % GD 76 |
| | | | | | | | | | | | | | | | | RCNLD | \$568,800 | |