

Key: 3364

Town of CHATHAM - Fiscal Year 2024

9/7/2023 9:38 am SEQ #: 3.655

LEG
AL
LAND

CURRENT OWNER				PARCEL ID				LOCATION				
LOST HORIZONS LLC 30 ALDRIN RD PLYMOUTH, MA 02360				15G-8-29				364 OLD HARBOR RD				
TRANSFER HISTORY				DOS	T	SALE PRICE	BK-PG (Cert)					
LOST HORIZONS LLC				11/18/2022	QS	4,090,000	35495-341					
BRIGHTON NIGEL J & AMANDA				12/06/2019	C	1,478,200	32523-267					
SMITH DAVID W & ANDREA				12/11/2012	C	1,750,000	26937-222					
CD	T	AC/SF/UN	Nbhd	Inf1	Inf2	ADJ BASE	SAF	Inf3	Lpi	VC	CREDIT AMT	ADJ VALUE
100	S	20,598	CH	1.00	100	916,250	1.73	100	1.00	MR1	2.50	750,500

CLASS	CLASS%	DESCRIPTION		BN ID	BN	CARD	
1010	100	SINGLE FAMILY			1	1 of 1	
PMT NO	PMT DT	TY	DESC	AMOUNT	INSP	BY	1st %
22-1093	01/18/2023	5	Demolitions	5,500			0 0
22-1046	12/09/2022	10	Reroof	1,500	02/16/2023	NF	100 100
22-957	11/15/2022	6	Pools etc	152,500	02/16/2023	NF	50 50
21-347	06/04/2020	3	Renovations	22,000	04/05/2022	NF	100 100
20-104	02/14/2020	3	Renovations	68,000	04/05/2022	NF	100 100

DE
TACH
ED

TOTAL	20,598 SF	ZONING	R40	FRNT	117	ASSESSED	CURRENT	PREVIOUS
Nbhd	CHATHAM	NOTE				LAND	750,500	600,400
Inf1	100		BUILDING	3,137,300	2,587,900			
Inf2	100		DETACHED	29,600	17,100			
			OTHER	0	0			
						TOTAL	3,917,400	3,205,400

TY	QUAL	COND	DIM/NOTE	YB	UNITS	ADJ PRICE	RCNLD
IPG	A	1.00	50 0.50 UC 16X36	2022	576	40.23	11,600
DGF	A	1.00	30 0.70 22X28	1980	616	41.65	18,000

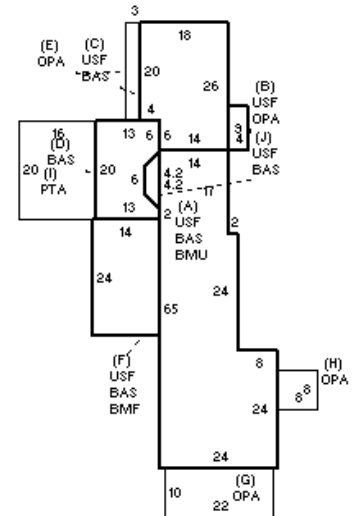

B
U
I
L
D
I
N
G

BUILDING	CD	ADJ	DESC	MEASURE	2/16/2023	NF
MODEL	1		RESIDENTIAL	LIST	2/16/2023	EST
STYLE	18	1.30	RENO'D ANTIQUE [100%]	REVIEW	3/16/2023	EMZ
QUALITY	V	2.35	VERY GOOD [100%]			
FRAME	1	1.00	WOOD FRAME [100%]			

BLDG COMMENTS
1EXFIX=PANTRY

YEAR BLT	1839	SIZE ADJ	1.000	ELEMENT	CD	DESCRIPTION	ADJ	S	BAT	T	DESCRIPTION	UNITS	YB	ADJ PRICE	RCN	TOTAL RCN	3,447,572			
NET AREA	4,279	DETAIL ADJ	1.365	FOUNDATION	4	FLR & WALL	1.00	A	BMU	N	BSMT UNFINISHED	1,198		163.56	195,945					
\$NLA(RCN)	\$806	OVERALL	1.000	EXT. COVER	2	CLAPBOARD	1.00	+	USF	L	UP-STRY FIN	1,705	1839	603.40	1,028,792					
				ROOF SHAPE	1	GABLE	1.00	+	OPA	N	OPEN PORCH	380		178.84	67,957					
				ROOF COVER	1	ASPH/CMP SHIN	1.00	C	BAS	L	BAS AREA	444	2012	711.11	315,732					
				FLOOR COVER	1	HARDWOOD	1.00	+	BAS	L	BAS AREA	569	1989	711.10	404,618					
				INT. FINISH	1	PLASTER	1.00	F	BMF	N	BSMT FINISH-SEP	336		255.21	85,752					
				HEATING/COOL	11	HT-WT/COOL AIR	1.05	F	USF	L	UP-STRY FIN	336	1989	603.40	202,742					
				FUEL SOURCE	2	GAS	1.00	I	PTA	N	PATIO/STOOP	320		42.07	13,461					
								+	BAS	L	BAS AREA	1,225	1839	711.11	871,105					
									F21	O	FPL 2S 1OP	4		24,383.60	97,534					
									GFP	O	GAS LOG/FP/E FP	7		14,620.70	102,345					
																COND	9 9 %			
																FUNC	0			
																ECON	0			
																DEPR	9 % GD	91		
																RCNLD				\$3,137,300