

Key: 3720

Town of CHATHAM - Fiscal Year 2024

9/7/2023 9:38 am SEQ #: 4.052

LEGAL

LAND

DETACHED

BUILDING

CURRENT OWNER				PARCEL ID				LOCATION				
GEOFFREY E SNYDER & KATHLEEN C FAM TRUST SNYDER GEOFFREY E & KATHLEEN C TRSTES 931 CAST IRON CT FT MILL, SC 29708				16C-24C-62B				83 WATER ST				
TRANSFER HISTORY				DOS	T	SALE PRICE	BK-PG (Cert)					
GEOFFREY E SNYDER & KATHL				02/01/2021	A	1	33749-18					
SNYDER GEOFFREY & KATHLEE				02/17/1998	D	272,500	11227-325					
BORGAL GERALD E				08/29/1997	99	210,000	10927-206					
CD	T	AC/SF/UN	Nbhd	Inf1	Inf2	ADJ BASE	SAF	Inf3	Lpi	VC	CREDIT AMT	ADJ VALUE
100	S	27,405	CH	1.00	100	1,374,375	1.36	100	1.00	R10	3.75	1,179,570

CLASS	CLASS%	DESCRIPTION			BN ID	BN	CARD	
1010	100	SINGLE FAMILY				1	1 of 1	
PMT NO	PMT DT	TY	DESC	AMOUNT	INSP	BY	1st	%
23-380	04/20/2023	97	WEATHERIZATI	6,159			100	100
15-654	10/26/2015	3	Renovations	41,460	02/21/2017	MR	100	100
11-207	05/23/2011	2	Additions	25,000	04/17/2012	MR	100	100
	02/19/2004	50	Meas & List			RRC	100	100
03-655	12/19/2003	2	Additions	135,000			100	100

TOTAL	27,405 SF	ZONING	R20	FRNT	0	ASSESSED	CURRENT	PREVIOUS
Nbhd	CHATHAM	N O T E	Dist Ocn Wv/panhandle Lot/Ar Plan 3/92 Lot2			LAND	1,179,600	982,900
Inf1	100		LAND	2,592,600	2,157,600			
Inf2	100		OTHER	0	0			
			TOTAL	3,772,200	3,140,500			

TY	QUAL	COND	DIM/NOTE	YB	UNITS	ADJ PRICE	RCNLD



BLDG COMMENTS

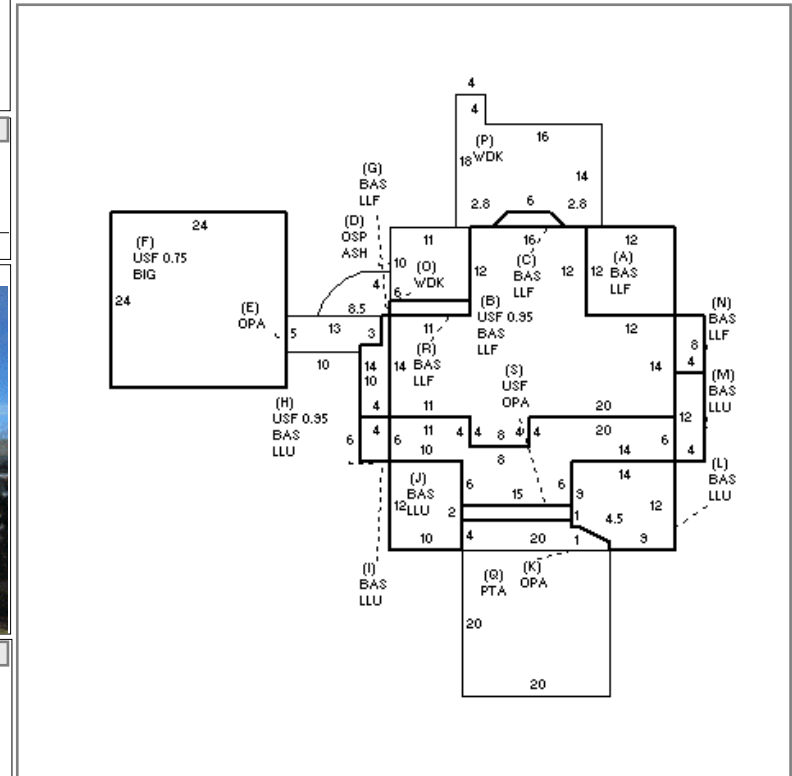

BUILDING	CD	ADJ	DESC	MEASURE	2/21/2017	MR
MODEL	1		RESIDENTIAL	LIST	2/21/2017	EST
STYLE	19	1.30	NEW STYLE [100%]	REVIEW	10/12/2021	APK
QUALITY	V	2.35	VERY GOOD [100%]			
FRAME	1	1.00	WOOD FRAME [100%]			

YEAR BLT	2001	SIZE ADJ	1.000	ELEMENT	CD	DESCRIPTION	ADJ	S	BAT	T	DESCRIPTION	UNITS	YB	ADJ PRICE	RCN	TOTAL RCN	3,123,670					
NET AREA	3,140	DETAIL ADJ	1.352	FOUNDATION	4	FLR & WALL	1.00	+	LLF	N	LOWER LEVEL FIN	258		513.62	132,514							
\$NLA(RCN)	\$995	OVERALL	1.000	EXT. COVER	1	WOOD SHINGLE	1.00	+	BAS	L	BAS AREA	1,669	2001	697.92	1,164,834							
				ROOF SHAPE	1	GABLE	1.00	B	LLF	N	LOWER LEVEL FIN	770		513.62	395,486							
				ROOF COVER	2	WOOD SHIN	1.01	+	USF	L	UP-STRY FIN	1,039	2001	592.21	615,308							
				FLOOR COVER	26	SOFTWD/OTHER	1.00	D	ASH	N	ATT SHED	110		142.41	15,665							
				INT. FINISH	2	DRYWALL	1.00	D	OSP	N	OPEN SCR PORCH	110		185.18	20,370							
				HEATING/COOL	9	WARM/COOL AIR	1.03	+	OPA	N	OPEN PORCH	163		178.83	29,149							
				FUEL SOURCE	2	GAS	1.00	F	BIG	N	BUILT-IN GARAGE	576		181.35	104,455							
													F	USF	L	UP-STRY FIN	432	2003	592.21	255,835		
													+	LLU	N	LOWER LEVEL UN	641		393.24	252,066		
													+	WDK	N	WOOD DECK	328		137.24	45,014		
													Q	PTA	N	PATIO/STOOP	400		42.07	16,826		
													F21	O	FPL 2S 1OP	1		24,383.60	24,384			
													ODS	O	OUT DOOR SHWR-A	1		3,471.00	3,471			
																COND	17	17 %				
																FUNC	0					
																ECON	0					
																DEPR	17	% GD	83			
																RCNLD				\$2,592,600		