

Key: 3801

Town of CHATHAM - Fiscal Year 2024

9/7/2023 9:38 am SEQ #: 4.142

LEGAL

LAND

DETACHED

BUILDING

CURRENT OWNER				PARCEL ID				LOCATION			
WOOD PAMELA & KIRCH BRUCE 269 MERRIAM ST WESTON, MA 02493-1822				16C-8A-W2				24 WILDERWOOD LN			
TRANSFER HISTORY				DOS	T	SALE PRICE	BK-PG (Cert)				
WOOD PAMELA & KIRCH BRUCE				12/19/2005	A		1 20582-130				
WOOD PAMELA				05/31/1989	A		6756-333				

CLASS	CLASS%	DESCRIPTION			BN ID	BN	CARD	
1010	100	SINGLE FAMILY				1	1 of 1	
PMT NO	PMT DT	TY	DESC	AMOUNT	INSP	BY	1st	%
00000870	03/17/2006	50	Meas & List			RRC	100	100
	02/11/2005	50	Meas & List			RRC	100	100
	01/04/2005	1	New Construc	287,000			100	100
00000847	01/04/2005	5	Demolitions	5,000			100	100
P2005012	12/17/2004	5	Demolitions	5,000			100	100

CD	T	AC/SF/UN	Nbhd	Inf1	Inf2	ADJ BASE	SAF	Inf3	Lpi	VC	CREDIT AMT	ADJ VALUE
100	S	10,500	CH	1.00	100	1.00	100	1.00	R10	3.75		1,017,720

TOTAL	10,500 SF	ZONING	R20	FRNT	75	ASSESSED	CURRENT	PREVIOUS
Nbhd	CHATHAM	NOTE				LAND	1,017,700	848,100
Inf1	100		BUILDING	680,600	627,000			
Inf2	100		DETACHED	0	0			
			OTHER	0	0			
				TOTAL		1,698,300	1,475,100	

TY	QUAL	COND	DIM/NOTE	YB	UNITS	ADJ PRICE	RCNLD

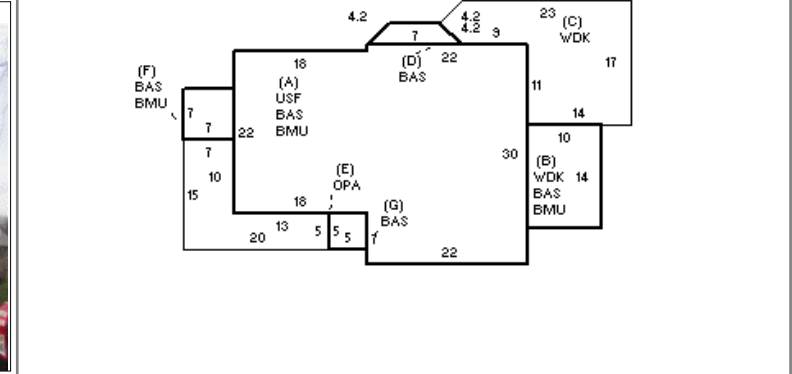

BUILDING	CD	ADJ	DESC	MEASURE	1/21/2022	NF
MODEL	1		RESIDENTIAL	LIST	1/21/2022	EST
STYLE	5	1.00	COLONIAL [100%]	REVIEW	2/9/2022	EMZ
QUALITY	+	1.20	PLUS AVE [100%]			
FRAME	1	1.00	WOOD FRAME [100%]			

BLDG COMMENTS

YEAR BLT	2005	SIZE ADJ	1.000
NET AREA	2,356	DETAIL ADJ	1.030
\$NLA(RCN)	\$348	OVERALL	1.000
CAPACITY		UNITS	ADJ
STORIES		2	1.00
ROOMS		10	1.00
BEDROOMS		3	1.00
FULL BATHS		3	1.00
1/2 BATHS		0	1.00
FIXTURES		10	\$9,888
UNITS		1	1.00

ELEMENT	CD	DESCRIPTION	ADJ
FOUNDATION	4	FLR & WALL	1.00
EXT. COVER	1	WOOD SHINGLE	1.00
ROOF SHAPE	1	GABLE	1.00
ROOF COVER	1	ASPH/CMP SHIN	1.00
FLOOR COVER	1	HARDWOOD	1.00
INT. FINISH	2	DRYWALL	1.00
HEATING/COOL	9	WARM/COOL AIR	1.03
FUEL SOURCE	2	GAS	1.00

S	BAT	T	DESCRIPTION	UNITS	YB	ADJ PRICE	RCN
+	BMU	N	BSMT UNFINISHED	1,245		82.93	103,254
A	USF	L	UP-STRY FIN	1,056	2005	249.69	263,675
+	WDK	N	WOOD DECK	441		70.08	30,905
+	BAS	L	BAS AREA	1,300	2005	294.26	382,542
E	OPA	N	OPEN PORCH	170		91.32	15,524
F21	O		FPL 2S 1OP	1		12,451.20	12,451
ODS	O		OUT DOOR SHWR-A	1		1,772.40	1,772

TOTAL RCN	820,012
CONDITION ELEM	CD
EXTERIOR	A
INTERIOR	A
KITCHEN	A
BATHS	A
HEAT	A
ELECT	A
EFF.YR/AGE	2005 / 17
COND	17 17 %
FUNC	0
ECON	0
DEPR	17 % GD 83
RCNLD	\$680,600