

Key: 3954

Town of CHATHAM - Fiscal Year 2024

9/7/2023 9:38 am SEQ #: 4.327

LEGAL

LAND

DETACHED

BUILDING

CURRENT OWNER				PARCEL ID				LOCATION					
UPLAND ROAD LIVING TRUST & SHORE ROAD LIVING TRUST				16G-16-T3				552 SHORE RD					
552 SHORE RD CHATHAM, MA 02633				TRANSFER HISTORY				DOS	T	SALE PRICE	BK-PG (Cert)		
				UPLAND ROAD LIVING TRUST				10/12/2012	A	1	26755-74		
				CLEMENTS BETTY M				12/23/1980	A	1	3221-196		

CLASS	CLASS%	DESCRIPTION			BN ID	BN	CARD	
1010	100	SINGLE FAMILY				1	1 of 1	
PMT NO	PMT DT	TY	DESC	AMOUNT	INSP	BY	1st	%
11-138	04/12/2011	51	Meas		03/04/2013	MR	100	100
06-015	01/13/2006	10	Reroof	35,000	04/18/2012	MR	100	100
	03/05/2004	50	Meas & List	15,000	02/07/2007		100	100
P2002295	11/14/2002	99	n/a			AM	100	100

CD	T	AC/SF/UN	Nbhd	Inf1	Inf2	ADJ BASE	SAF	Inf3	Lpi	VC	CREDIT AMT	ADJ VALUE
100	S	40,000	CH	1.00	100	1.00	100	1.00	OF5	15.50		5,216,480
300	A	1,944	CH	1.00	100	1.00	100	1.00	OF5	15.50		578,530

TOTAL	2.862 Acres	ZONING	R40	FRNT	0	ASSESSED	CURRENT	PREVIOUS
Nbhd	CHATHAM	NOTE				LAND	5,795,000	5,919,400
Inf1	100		BUILDING	2,506,300	2,134,800			
Inf2	100		DETACHED	6,100	5,800			
			OTHER	0	0			
						TOTAL	8,307,400	8,060,000

TY	QUAL	COND	DIM/NOTE	YB	UNITS	ADJ PRICE	RCNLD
PTD	A	1.00	40 0.60	1965	665	11.30	4,500
SHF	A	1.00	20 0.80	1991	160	12.30	1,600



BLDG COMMENTS
2/15/22-REFUSED PICS

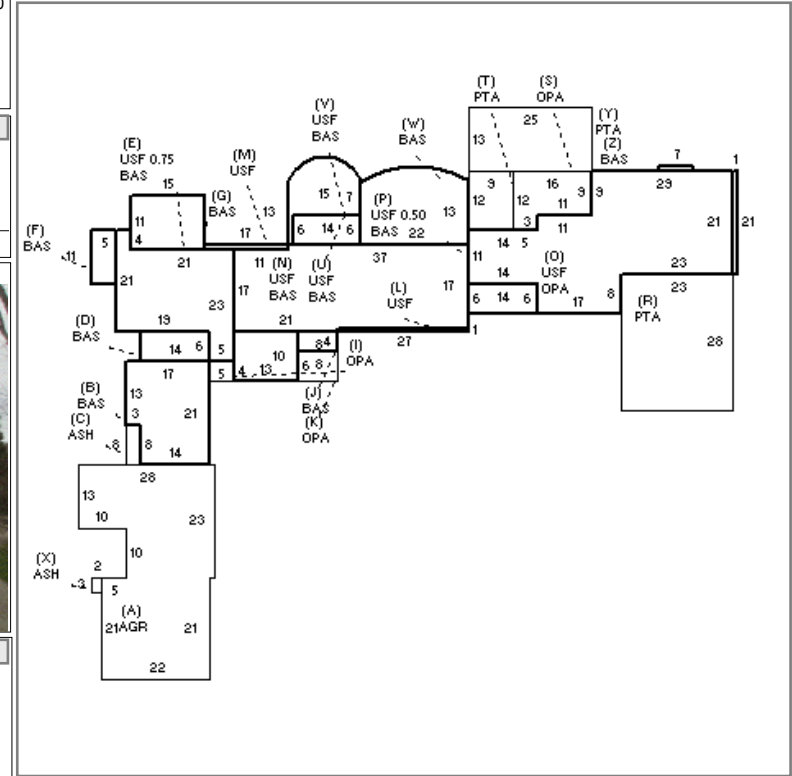

BUILDING	CD	ADJ	DESC	MEASURE	2/16/2022	NF
MODEL	1		RESIDENTIAL	LIST	2/16/2022	EST
STYLE	7	1.00	OLD STYLE [100%]	REVIEW	2/24/2022	EMZ
QUALITY	V	2.35	VERY GOOD [100%]			
FRAME	1	1.00	WOOD FRAME [100%]			

YEAR BLT	1930	SIZE ADJ	1.000	ELEMENT	CD	DESCRIPTION	ADJ	S	BAT	T	DESCRIPTION	UNITS	YB	ADJ PRICE	RCN	TOTAL RCN	3,213,186
NET AREA	5,868	DETAIL ADJ	1.010	FOUNDATION	4	FLR & WALL	1.00	A	AGR	N	ATTACHED GARAGE	1,006		173.78	174,826		
\$NLA(RCN)	\$548	OVERALL	1.000	EXT. COVER	1	WOOD SHINGLE	1.00	+	BAS	L	BAS AREA	3,693	1930	513.60	1,896,711		
				ROOF SHAPE	1	GABLE	1.00	+	ASH	N	ATT SHED	30		142.41	4,272		
				ROOF COVER	2	WOOD SHIN	1.01	+	OPA	N	OPEN PORCH	311		178.83	55,618		
				FLOOR COVER	1	HARDWOOD	1.00	+	USF	L	UP-STRY FIN	2,175	1930	435.80	947,873		
				INT. FINISH	1	PLASTER	1.00	+	PTA	N	PATIO/SOOP	1,077		42.06	45,303		
				HEATING/COOL	2	HOT WATER	1.00	F21	O	FPL 2S 1OP	1		24,383.60	24,384			
				FUEL SOURCE	2	GAS	1.00	F22	O	FPL 2S 2OP	1		34,145.50	34,146			
								GEN	O	GENERATOR	1		0.00				
								ODS	O	OUT DOOR SHWR-A	1		3,471.00	3,471			
																CONDITION ELEM	CD
																EXTERIOR	A
																INTERIOR	G
																KITCHEN	G
																BATHS	G
																HEAT	U
																ELECT	U
																EFF.YR/AGE	1997 / 25
																COND	22 22 %
																FUNC	0
																ECON	0
																DEPR	22 % GD 78
																RCNLD	\$2,506,300