

Key: 3966

Town of CHATHAM - Fiscal Year 2024

9/7/2023 9:38 am SEQ #: 4.339

LEGAL

LAND

DETACHED

BUILDING

CURRENT OWNER				PARCEL ID				LOCATION			
MADAR WILLIAM P & AMANDA 114 LITTLE HARBOR WAY CHESTERTOWN, MD 21620				16G-6-K4				31 THAYER LN			
TRANSFER HISTORY				DOS	T	SALE PRICE	BK-PG (Cert)				
MADAR WILLIAM P & AMANDA				06/17/2014	R	1	28208-345				
MADAR AMANDA C & JOSIAH R				06/17/2014	R	1	28208-334				
MADAR WILLIAM CHASE & JOS				06/17/2014	A	1	28208-330				

CLASS	CLASS%	DESCRIPTION			BN ID	BN	CARD	
1010	100	SINGLE FAMILY				1	1 of 1	
PMT NO	PMT DT	TY	DESC	AMOUNT	INSP	BY	1st	%
14-801	12/24/2014	2	Additions	50,000	06/07/2016	WFF	100	100
01-565	05/16/2008	50	Meas & List			RRC	100	100
	11/16/2001	99	n/a	135,000			100	100

CD	T	AC/SF/UN	Nbhd	Inf1	Inf2	ADJ BASE	SAF	Inf3	Lpi	VC	CREDIT AMT	ADJ VALUE
100	S	40,000	NC	1.00	100	1.00	100	1.00	11.00	OF6	11.00	3,702,020
300	A	0.041	NC	1.00	100	1.00	100	1.00	11.00	OF6	11.00	8,660

TOTAL	41,780 SF	ZONING	R40	FRNT	0	ASSESSED	CURRENT	PREVIOUS
Nbhd	NORTH CHATHAM	NOTE Ocn Frt/Topo	LAND		3,710,700	3,092,100		
Inf1	100		BUILDING		834,600	759,600		
Inf2	100		DETACHED		0	0		
			OTHER		0	0		
TOTAL					4,545,300	3,851,700		

TY	QUAL	COND	DIM/NOTE	YB	UNITS	ADJ PRICE	RCNLD

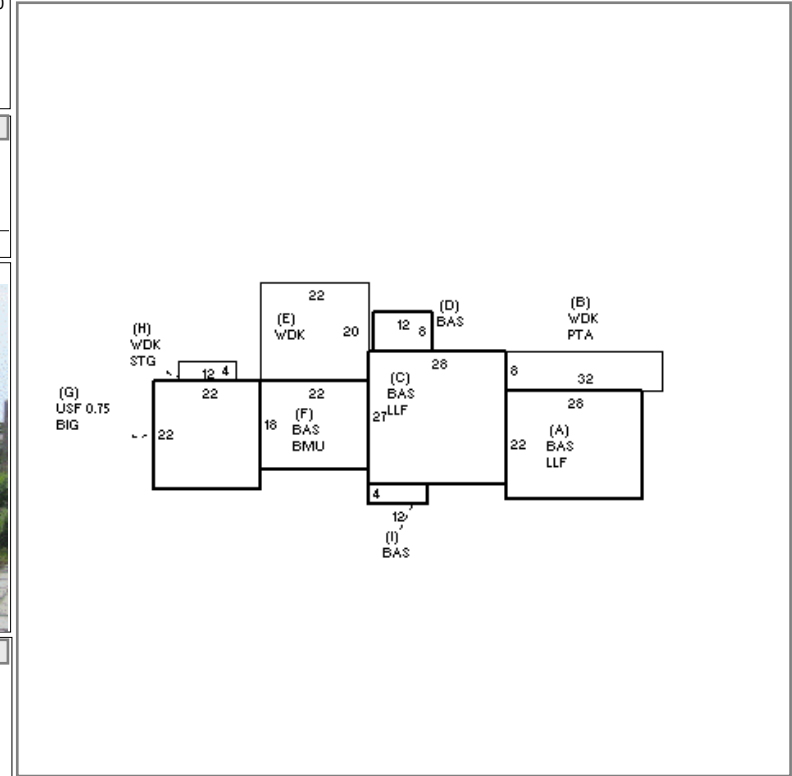

BUILDING	CD	ADJ	DESC	MEASURE	REVIEW	6/21/2016	TD
MODEL	1		RESIDENTIAL				
STYLE	4	1.00	CAPE [100%]				
QUALITY	+	1.20	PLUS AVE [100%]				
FRAME	1	1.00	WOOD FRAME [100%]				

BLDG COMMENTS

YEAR BLT	1965	SIZE ADJ	1.000	ELEMENT	CD	DESCRIPTION	ADJ	S	BAT	T	DESCRIPTION	UNITS	YB	ADJ PRICE	RCN	TOTAL RCN	1,098,206
NET AREA	2,275	DETAIL ADJ	1.060	FOUNDATION	4	FLR & WALL	1.00	+	LLF	N	LOWER LEVEL FIN	1,372		210.82	289,248		
\$NLA(RCN)	\$483	OVERALL	1.000	EXT. COVER	1	WOOD SHINGLE	1.00	B	PTA	N	PATIO/STOOP	256		21.48	5,498		
				ROOF SHAPE	1	GABLE	1.00	D	BAS	L	BAS AREA	96	2014	286.48	27,502		
				ROOF COVER	2	WOOD SHIN	1.01	+	WDK	N	WOOD DECK	744		70.08	52,140		
				FLOOR COVER	1	HARDWOOD	1.00	F	BMU	N	BSMT UNFINISHED	396		108.58	42,996		
				INT. FINISH	2	DRYWALL	1.00	G	BIG	N	BUILT-IN GARAGE	484		94.27	45,629		
				HEATING/COOL	11	HT-WT/COOL AIR	1.05	G	USF	L	UP-STRY FIN	363	1965	243.08	88,238		
				FUEL SOURCE	2	GAS	1.00	H	STG	N	STORAGE	48		47.05	2,258		
								+	BAS	L	BAS AREA	1,816	1965	286.47	520,235		
									PTA	N	PATIO/STOOP	200		21.48	4,296		
									F11	O	FPL 1S 1OP	1		8,972.40	8,972		

CONDITION ELEM	CD
EXTERIOR	
INTERIOR	
KITCHEN	
BATHS	
HEAT	
ELECT	

EFF.YR/AGE	1992 / 30
COND	24 24 %
FUNC	0
ECON	0
DEPR	24 % GD 76

RCNLD	\$834,600
-------	-----------