

Key: 3980

Town of CHATHAM - Fiscal Year 2024

9/7/2023 9:38 am SEQ #: 4.357

LEG
LAND

CURRENT OWNER				PARCEL ID				LOCATION				
EARLS MICHAEL 45 LUKE ST WRENTHAM, MA 02093				16H-2-3 543 OLD HARBOR RD								
TRANSFER HISTORY				DOS	T	SALE PRICE	BK-PG (Cert)					
EARLS MICHAEL				10/02/2020	V	1,399,000	(D1407864)					
TACOMA PARTNERS LIMITED P				02/23/2017	B	1	(D1315542)					
545 OLD HARBOR RD LLC				08/31/2016	V	1,700,000	(D1302578)					
CD	T	AC/SF/UN	Nbhd	Inf1	Inf2	ADJ BASE	SAF	Inf3	Lpi	VC	CREDIT AMT	ADJ VALUE
100	S	40,000	NC	1.00	100	1.00	100	1.00	OV1		3.50	1,177,920
300	A	1.171	NC	1.00	100	1.00	100	1.00	OV1		3.50	78,690

CLASS	CLASS%	DESCRIPTION			BN ID	BN	CARD	
1010	100	SINGLE FAMILY				1	1 of 1	
PMT NO	PMT DT	TY	DESC	AMOUNT	INSP	BY	1st	%
21-902	10/06/2021	14	DECK	10,000	04/12/2022	NF	100	100
21-742	08/18/2021	6	Pools etc	100,000	02/28/2023	NF	100	100
21-034	02/03/2021	3	Renovations	500,000	02/28/2023	NF	100	100
20-454	01/20/2021	5	Demolitions	19,000	04/08/2021	NF	100	100
20-068	11/19/2020	75	SPECIAL PERM				100	100

DE
TACH
ED

TOTAL	2.089 Acres	ZONING	R40	FRNT	0	ASSESSED	CURRENT	PREVIOUS
Nbhd	NORTH CHATHAM	N O T E	Ocn Ww/Swamp 1/3 Ownership In Lot at Cow Yard for Swim, Boat + Private Beach			LAND	1,256,600	1,047,100
Inf1	100		BUILDING	2,129,100	1,485,700			
Inf2	100		DETACHED	28,500	600			
			OTHER	0	0			
			TOTAL	3,414,200	2,533,400			

TY	QUAL	COND	DIM/NOTE	YB	UNITS	ADJ PRICE	RCNLD
SHF	A	1.00	70 0.30	1981	160	12.30	600
IPG	G	1.20	10 0.90 15X30	2022	450	51.32	20,800
HTB	G	1.20	10 0.90 7X7	2022	1	7,877.88	7,100

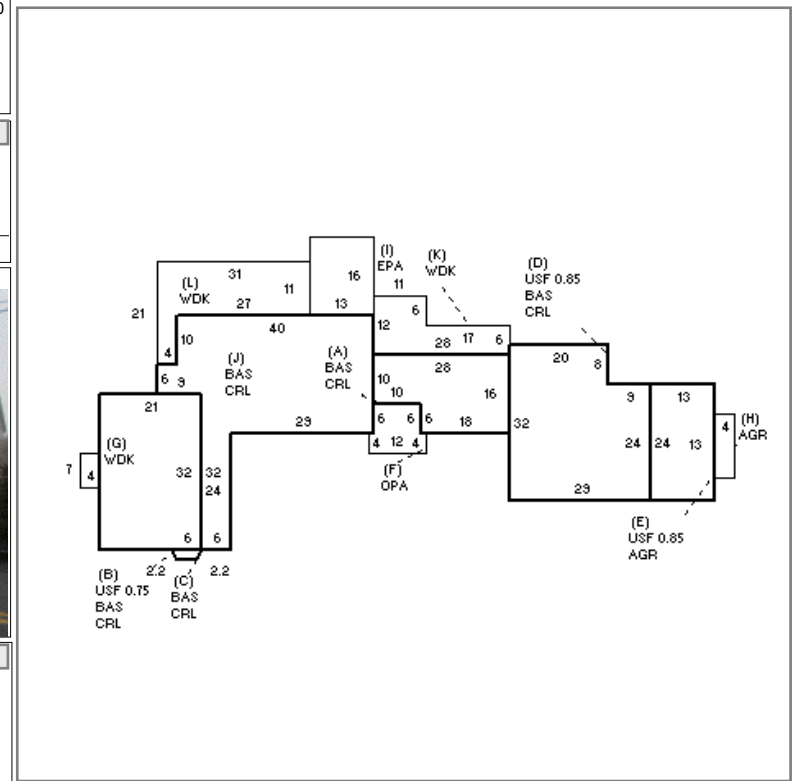

B
U
I
L
D
I
N
G

BUILDING	CD	ADJ	DESC	MEASURE	4/12/2022	NF
MODEL	1		RESIDENTIAL	LIST	4/12/2022	EST
STYLE	18	1.30	RENO'D ANTIQUE [100%]	REVIEW	3/17/2023	EMZ
QUALITY	G	1.44	GOOD [67%]			
FRAME	1	1.00	WOOD FRAME [100%]			

BLDG COMMENTS
INTERIOR EST PER PLANS (4/12/22)

YEAR BLT	1748	SIZE ADJ	1.000	ELEMENT	CD	DESCRIPTION	ADJ	S	BAT	T	DESCRIPTION	UNITS	YB	ADJ PRICE	RCN	TOTAL RCN	2,129,058		
NET AREA	4,511	DETAIL ADJ	1.365	FOUNDATION	6	CRAWL	1.00	+	CRL	N	CRAWL SPACE	3,014		26.14	78,786	CONDITION ELEM	CD		
\$NLA(RCN)	\$472	OVERALL	1.000	EXT. COVER	1	WOOD SHINGLE	1.00	A	BAS	L	BAS AREA	388	2021	432.25	167,714	EXTERIOR	G		
				ROOF SHAPE	1	GABLE	1.00	B	BAS	L	BAS AREA	672	1995	432.25	290,474	INTERIOR	G		
				ROOF COVER	1	ASPH/CMP SHIN	1.00	+	USF	L	UP-STRY FIN	1,497	2021	366.78	549,071	KITCHEN	G		
				FLOOR COVER	1	HARDWOOD	1.00	C	BAS	L	BAS AREA	10	1748	432.22	4,322	BATHS	G		
				INT. FINISH	2	DRYWALL	1.00	D	BAS	L	BAS AREA	856	1748	432.25	370,008	HEAT	U		
				HEATING/COOL	11	HT-WT/COOL AIR	1.05	+	AGR	N	ATTACHED GARAGE	364		116.98	42,581	ELECT	U		
				FUEL SOURCE	2	GAS	1.00	F	OPA	N	OPEN PORCH	108		109.21	11,794				
																		EFF.YR/AGE	2022 / 0
																		COND	0 0 %
																		FUNC	0
																		ECON	0
																		DEPR	0 % GD 100
																		RCNLD	\$2,129,100