

Key: 4079

Town of CHATHAM - Fiscal Year 2024

9/7/2023 9:38 am SEQ #: 4.481

LEGAL

CURRENT OWNER				PARCEL ID				LOCATION			
CAPE WATER ST TRUST ENLOW SUSAN & ROBINSON MELINDA TRSTES 300 E ASH SPRINGFIELD, IL 62703				17B-1-48				124 MAIN ST			
TRANSFER HISTORY				DOS	T	SALE PRICE	BK-PG (Cert)				

CLASS	CLASS%	DESCRIPTION			BN ID	BN	CARD	
1090	100	MULTIPLE HSES				2	2 of 2	
PMT NO	PMT DT	TY	DESC	AMOUNT	INSP	BY	1st	%

LAND

CD	T	AC/SF/UN	Nbhd	Inf1	Inf2	ADJ BASE	SAF	Inf3	Lpi	VC	CREDIT AMT	ADJ VALUE
----	---	----------	------	------	------	----------	-----	------	-----	----	------------	-----------

TOTAL	ZONING	FRNT	ASSESSED	CURRENT	PREVIOUS
Nbhd	NOTE		LAND	578,700	
Inf1		BUILDING			
Inf2		DETACHED			
			OTHER		
			TOTAL		

DETACHED

TY	QUAL	COND	DIM/NOTE	YB	UNITS	ADJ PRICE	RCNLD	PHOTO
								01/26/2022

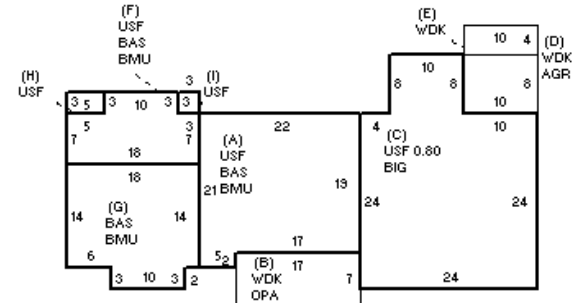

BUILDING

BUILDING	CD	ADJ	DESC	MEASURE	1/26/2022	NF
MODEL	1		RESIDENTIAL	LIST	1/26/2022	EST
STYLE	4	1.00	CAPE [100%]	REVIEW	2/10/2022	EMZ
QUALITY	+	1.20	PLUS AVE [100%]			
FRAME	1	1.00	WOOD FRAME [100%]			

BLDG COMMENTS

INDING

YEAR BLT	1993	SIZE ADJ	1.000	ELEMENT	CD	DESCRIPTION	ADJ	S	BAT	T	DESCRIPTION	UNITS	YB	ADJ PRICE	RCN	TOTAL RCN	761,437
NET AREA	1,999	DETAIL ADJ	1.060	FOUNDATION	4	FLR & WALL	1.00	+	BMU	N	BSMT UNFINISHED	866		89.95	77,898		
\$NLA(RCN)	\$381	OVERALL	1.000	EXT. COVER	1	WOOD SHINGLE	1.00	+	BAS	L	BAS AREA	866	1993	311.17	269,477		
CAPACITY			UNITS	ADJ	ROOF SHAPE	1	GABLE	1.00	B	OPA	N	OPEN PORCH		91.32	10,867		
STORIES	1.8		1.00	ROOF COVER	2	WOOD SHIN	1.01	C	BIG	N	BUILT-IN GARAGE	656		90.62	59,446		
ROOMS	7		1.00	FLOOR COVER	13	HARDWD/CARPET	1.00	D	AGR	N	ATTACHED GARAGE	80		90.62	7,249		
BEDROOMS	2		1.00	INT. FINISH	2	DRYWALL	1.00	+	WDK	N	WOOD DECK	239		70.08	16,750		
FULL BATHS	2		1.00	HEATING/COOL	11	HT-WT/COOL AIR	1.05	+	USF	L	UP-STRY FIN	1,133	1993	264.04	299,159		
1/2 BATHS	1		1.00	FUEL SOURCE	2	GAS	1.00		F21	O	FPL 2S 1OP	1		12,451.20	12,451		
FIXTURES	8	\$8,141															
UNITS	1	1.00															
																EFF.YR/AGE	1993 / 29
																COND	24 24 %
																FUNC	0
																ECON	0
																DEPR	24 % GD 76
																RCNLD	\$578,700