

Key: 43

Town of CHATHAM - Fiscal Year 2024

9/7/2023 9:38 am SEQ #: 49

LEGAL

CURRENT OWNER				PARCEL ID				LOCATION			
BARRETT SCOTT A PO BOX 932 W CHATHAM, MA 02669-0932				10B-28-B27				48 AUNT NABBYS LN			
TRANSFER HISTORY				DOS	T	SALE PRICE	BK-PG (Cert)				
BARRETT SCOTT A				05/03/2017	H	1 (212775)					
BARRETT SCOTT A & GAIL E				06/12/1997	99	215,000 (144758)					
BERDIK RICHARD F & JEANNE				07/11/1978	A	22,750 (74826)					

CLASS	CLASS%	DESCRIPTION			BN ID	BN	CARD	
1010	100	SINGLE FAMILY				1	1 of 2	
PMT NO	PMT DT	TY	DESC	AMOUNT	INSP	BY	1st	%
20-473	01/05/2021	12	INSULATION	3,200	04/23/2021	NF	100	100
21-363	06/12/2020	3	Renovations	10,500	04/23/2021	NF	100	100
19-179	03/20/2019	3	Renovations	100,000	04/26/2022	NF	100	100
18-397	05/23/2018	3	Renovations	43,463	02/26/2020	TCK	100	100
14-268	05/13/2014	2	Additions	83,514	04/14/2014	MW	100	100

LAND

CD	T	AC/SF/UN	Nbhd	Inf1	Inf2	ADJ BASE	SAF	Inf3	Lpi	VC	CREDIT AMT	ADJ VALUE	
100	S	27,270 WC	1.00	100	1.00	100	1.00	641,375	1.37	100	1.00	R06 1.75	550,000

TOTAL	27,270 SF	ZONING	R20	FRNT	0	ASSESSED	CURRENT	PREVIOUS
Nbhd	WEST CHATHAM	NOTE Deded Rec Rts PL105/27 Lot29	LAND	550,000	458,300			
Inf1	100		BUILDING	565,700	520,300			
Inf2	100		DETACHED	0	0			
			OTHER	159,200	146,400			
			TOTAL	1,274,900	1,125,000			

DETAILED

TY	QUAL	COND	DIM/NOTE	YB	UNITS	ADJ PRICE	RCNLD	PHOTO
								04/28/2022

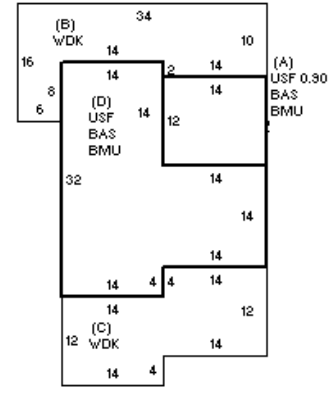

BUILDING	CD	ADJ	DESC	MEASURE		
MODEL	1		RESIDENTIAL	LIST		
STYLE	8	0.95	CONTEMPORARY [100%]	REVIEW	5/11/2022	MR
QUALITY	+	1.20	PLUS AVE [100%]			
FRAME	1	1.00	WOOD FRAME [100%]			

YEAR BLT	1980	SIZE ADJ	1.000	ELEMENT	CD	DESCRIPTION	ADJ	S	BAT	T	DESCRIPTION	UNITS	YB	ADJ PRICE	RCN	TOTAL RCN	577,230
NET AREA	1,607	DETAIL ADJ	0.950	FOUNDATION	4	FLR & WALL	1.00	+	BMU	N	BSMT UNFINISHED	812		91.54	74,329		
\$NLA(RCN)	\$359	OVERALL	1.000	EXT. COVER	1	WOOD SHINGLE	1.00	+	BAS	L	BAS AREA	812	1980	290.96	236,258		
				ROOF SHAPE	1	GABLE	1.00	+	USF	L	UP-STRY FIN	795	1980	246.89	196,276		
				ROOF COVER	1	ASPH/CMP SHIN	1.00	+	WDK	N	WOOD DECK	684		70.08	47,935		
				FLOOR COVER	26	SOFTWD/OTHER	1.00		F21	O	FPL 2S 1OP	1		12,451.20	12,451		
				INT. FINISH	2	DRYWALL	1.00		ODS	O	OUT DOOR SHWR-A	1		1,772.40	1,772		
				HEATING/COOL	1	FORCED AIR	1.00										
				FUEL SOURCE	2	GAS	1.00										

BUILDING

CONDITION ELEM	CD	
EXTERIOR	V	
INTERIOR	V	
KITCHEN	V	
BATHS	V	
HEAT	U	
ELECT	U	
EFF.YR/AGE	2020 / 2	
COND	2	2 %
FUNC	0	
ECON	0	
DEPR	2	% GD 98
RCNLD	\$565,700	

