

Key: 482

Town of CHATHAM - Fiscal Year 2024

9/7/2023 9:38 am SEQ #: 552

LEGAL

LAND

CURRENT OWNER				PARCEL ID				LOCATION				
SHAKESPEARE WILLIAM & BETINA 2 HUBLEY LN SOUTHBOROUGH, MA 01772-1991				11A-16A-F11				87 MOONCUSSERS LN				
TRANSFER HISTORY				DOS	T	SALE PRICE	BK-PG (Cert)					
SHAKESPEARE WILLIAM & BET				05/12/2017	H	935,000	(212872)					
COMFORT ROBIN HESS				07/01/2003	QS	740,000	(169709)					
MUNSON				09/12/1994	A	1	(134968)					

CLASS	CLASS%	DESCRIPTION			BN ID	BN	CARD	
1010	100	SINGLE FAMILY				1	1 of 1	
PMT NO	PMT DT	TY	DESC	AMOUNT	INSP	BY	1st	%
19-325	05/09/2019	2	Additions	387,000	01/30/2020	NF	100	100
18-1040	12/14/2018	3	Renovations	130,679	01/17/2019	TCK	100	100
18-090	12/06/2018	75	SPECIAL PERM				100	100
	06/23/2017	98	SALES QUESTI				0	0
12-056	02/03/2012	2	Additions	359,000	07/10/2013	SF	100	100

CD	T	AC/SF/UN	Nbhd	Inf1	Inf2	ADJ BASE	SAF	Inf3	Lpi	VC	CREDIT AMT	ADJ VALUE
100	S	40,000	CH 1.00	85	0.85	1,246,100	1.00	100	1.00	R11	4.00	1,144,260
300	A	0.519	CH 1.00	100	1.00	76,800	1.00	100	1.00	R11	4.00	39,860

TOTAL	1.437 Acres	ZONING	R40	FRNT	0	ASSESSED	CURRENT	PREVIOUS
Nbhd	CHATHAM	N O T E INFL2=WETLANDS. Driveway easement over lot 15 LCP16879_M DEEDED ACCESS TO OYESTER RIVER	LAND	1,184,100	986,700			
Inf1	85		BUILDING	1,038,200	944,800			
Inf2	100		DETACHED	0	0			
			OTHER	0	0			
TOTAL				2,222,300	1,931,500			

TY	QUAL	COND	DIM/NOTE	YB	UNITS	ADJ PRICE	RCNLD

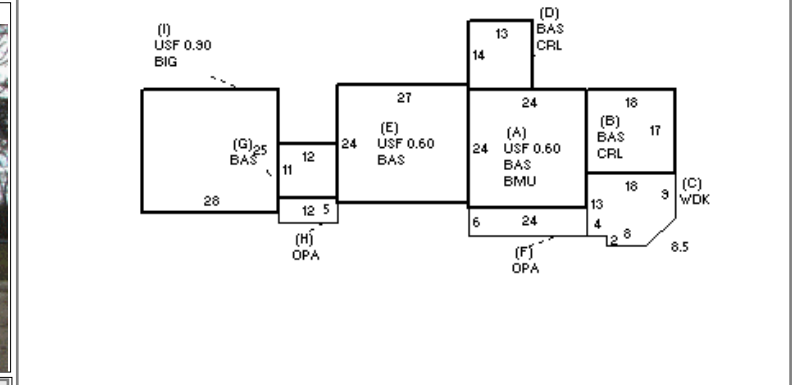

BUILDING	CD	ADJ	DESC	MEASURE	1/30/2020	NF
MODEL	1		RESIDENTIAL	LIST	7/10/2013	SF
STYLE	4	1.00	CAPE [100%]	REVIEW	2/24/2020	MR
QUALITY	+	1.20	PLUS AVE [100%]			
FRAME	1	1.00	WOOD FRAME [100%]			

BLDG COMMENTS
INFO @ DOOR (07/2013)
INT EST FROM PLANS 2/2020

DETACHED

BUILDING

YEAR BLT	1956	SIZE ADJ	1.000	ELEMENT	CD	DESCRIPTION	ADJ	S	BAT	T	DESCRIPTION	UNITS	YB	ADJ PRICE	RCN	TOTAL RCN	1,038,150			
NET AREA	3,209	DETAIL ADJ	1.030	FOUNDATION	4	FLR & WALL	1.00	A	BMU	N	BSMT UNFINISHED	576		85.69	49,358	CONDITION ELEM	CD			
\$NLA(RCN)	\$324	OVERALL	1.000	EXT. COVER	1	WOOD SHINGLE	1.00	A	BAS	L	BAS AREA	576	1956	282.42	162,672	EXTERIOR	V			
				ROOF SHAPE	1	GABLE	1.00	A	USF	L	UP-STRY FIN	346	1956	239.64	82,915	INTERIOR	V			
				ROOF COVER	1	ASPH/CMP SHIN	1.00	+	CRL	N	CRAWL SPACE	488		25.49	12,437	KITCHEN	G			
				FLOOR COVER	1	HARDWOOD	1.00	B	BAS	L	BAS AREA	306	2012	282.42	86,419	BATHS	G			
				INT. FINISH	2	DRYWALL	1.00	C	WDK	N	WOOD DECK	244		70.08	17,100	HEAT	U			
				HEATING/COOL	9	WARM/COOL AIR	1.03	D	BAS	L	BAS AREA	182	1999	282.42	51,400	ELECT	U			
				FUEL SOURCE	2	GAS	1.00	+	BAS	L	BAS AREA	780	2019	282.42	220,285					
																		EFF.YR/AGE	2022 / 0	
																		COND	0 0 %	
																		FUNC	0	
																		ECON	0	
																		DEPR	0 % GD 100	
																		RCNLD	\$1,038,200	