

Key: 4891

Town of CHATHAM - Fiscal Year 2024

9/7/2023 9:38 am SEQ #: 5.327

LEGAL

LAND

DETACHED

BUILDING

CURRENT OWNER				PARCEL ID				LOCATION			
CYNTHIA DOHERTY REVOCABLE TRUST DOHERTY F NEIL & MATTHEW C TRSTES 1651 BEACH RD UNIT 405 ENGLEWOOD, FL 34223				3F-1-D19				321 MORTON RD			
TRANSFER HISTORY				DOS	T	SALE PRICE	BK-PG (Cert)				
CYNTHIA DOHERTY REVOCABLE				06/18/2019	H		(219718)				
DOHERTY CYNTHIA E				08/31/1998	99	143,000	(149937)				
NOWAK CURTIS				05/10/1983	QS	72,500	(91813)				

CLASS	CLASS%	DESCRIPTION			BN ID	BN	CARD	
1010	100	SINGLE FAMILY				1	1 of 1	
PMT NO	PMT DT	TY	DESC	AMOUNT	INSP	BY	1st	%
07-150	02/07/2008	50	Meas & List			RRC	100	100
	04/02/2007	2	Additions	15,000	02/07/2008	RRC	100	100
	04/12/2005	50	Meas & List			RRC	100	100
P2004080	02/20/2004	4	Outbuildings	2,880	02/07/2008		100	100
03-536	10/27/2003	10	Reroof	6,000	02/07/2008		100	100

CD	T	AC/SF/UN	Nbhd	Inf1	Inf2	ADJ BASE	SAF	Inf3	Lpi	VC	CREDIT AMT	ADJ VALUE
100	S	10,235	MC	1.00	1.00	366,500	3.14	1.00	MR2	1.00		270,410

TOTAL	10,235 SF	ZONING	R60	FRNT	115	ASSESSED	CURRENT	PREVIOUS
Nbhd	MID CHATHAM	NOTE			LAND	270,400	191,500	
Inf1	100		BUILDING	349,400	318,000			
Inf2	100		DETACHED	1,100	1,000			
			OTHER	0	0			
TOTAL					620,900	510,500		

TY	QUAL	COND	DIM/NOTE	YB	UNITS	ADJ PRICE	RCNLD
SHF	A	1.00	20 0.80 8X12	2004	96	14.26	1,100



BLDG COMMENTS

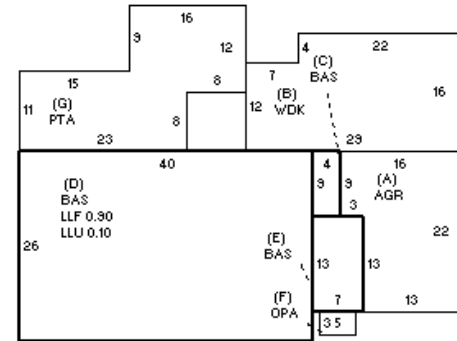

BUILDING	CD	ADJ	DESC	MEASURE	10/25/2019	NF
MODEL	1		RESIDENTIAL	LIST	10/25/2019	EST
STYLE	1	0.85	RANCH [100%]	REVIEW	11/12/2019	EMZ
QUALITY	A	1.00	AVERAGE [100%]			
FRAME	1	1.00	WOOD FRAME [100%]			

YEAR BLT	1982	SIZE ADJ	1.000	ELEMENT	CD	DESCRIPTION	ADJ	S	BAT	T	DESCRIPTION	UNITS	YB	ADJ PRICE	RCN	TOTAL RCN	478,567	
NET AREA	1,167	DETAIL ADJ	0.875	FOUNDATION	4	FLR & WALL	1.00	A	AGR	N	ATTACHED GARAGE	313		83.52	26,142	CONDITION ELEM	CD	
\$NLA(RCN)	\$410	OVERALL	1.000	EXT. COVER	1	WOOD SHINGLE	1.00	B	WDK	N	WOOD DECK	436		58.40	25,462	EXTERIOR	A	
CAPACITY			UNITS	ADJ	ROOF SHAPE	1	GABLE	1.00	+	BAS	L	BAS AREA	1,167	1982	210.52	245,681	INTERIOR	A
STORIES	1	1.00	ROOF COVER	1	ASPH/CMP SHIN	1.00	D	LLU	N	LOWER LEVEL UN	104		118.62	12,336	KITCHEN	A		
ROOMS	6	1.00	FLOOR COVER	13	HARDWD/CARPET	1.00	D	LLF	N	LOWER LEVEL FIN	936		154.93	145,014	BATHS	A		
BEDROOMS	2	1.00	INT. FINISH	2	DRYWALL	1.00	F	OPA	N	OPEN PORCH	15		76.13	1,142	HEAT	A		
FULL BATHS	3	1.00	HEATING/COOL	9	WARM/COOL AIR	1.03	G	PTA	N	PATIO/STOOP	421		17.90	7,536	ELECT	A		
1/2 BATHS	0	1.00	FUEL SOURCE	2	GAS	1.00		F11	O	FPL 1S 1OP	1		7,477.00	7,477				
FIXTURES	9	\$6,300						ODS	O	OUT DOOR SHWR-A	1		1,477.00	1,477				
UNITS	1	1.00																
																EFF.YR/AGE	1982 / 40	
																COND	27 27 %	
																FUNC	0	
																ECON	0	
																DEPR	27 % GD 73	
																RCNLD	\$349,400	