

Key: 4986

Town of CHATHAM - Fiscal Year 2024

9/7/2023 9:38 am SEQ #: 5.424

LEGAL

LAND

DETACHED

BUILDING

CURRENT OWNER				PARCEL ID				LOCATION			
WALKER MARGARET D & WALKER CHRISTOPHER J 197 NORTH ST HINGHAM, MA 02043-1871				4C-16A-E3				31 GILLIS RD			
TRANSFER HISTORY				DOS	T	SALE PRICE		BK-PG (Cert)			
WALKER MARGARET D & KENNARD SPENCER & MARSHAL				12/21/2020	QS	850,000		33594-59			
KENNARD MARGARETT M				05/11/2019	H	31261-98		9 23488-174			
KENNARD MARGARETT M				02/27/2009	A						

CLASS	CLASS%	DESCRIPTION			BN ID	BN	CARD	
1010	100	SINGLE FAMILY				1	1 of 2	
PMT NO	PMT DT	TY	DESC	AMOUNT	INSP	BY	1st	%
23-387	04/24/2023	77	SOLAR PANELS	26,640				0 0
22-469	06/30/2022	3	Renovations	475,000	03/23/2023	NF	60	60
21-1146	12/14/2021	3	Renovations	150,000	03/23/2023	NF	80	90
13-262	05/15/2013	10	Reroof	6,200	04/22/2014	MR	100	100
	03/07/2006	50	Meas & List			JB	100	100

TOTAL	13,080 SF	ZONING	R20	FRNT	169	ASSESSED	CURRENT	PREVIOUS
Nbhd	SOUTH CHATHAM	NOTE				LAND	840,400	700,300
Inf1	100		LAND	509,200	179,900			
Inf2	100		DETACHED	0	17,300			
			OTHER	180,900	0			
						TOTAL	1,530,500	897,500

TY	QUAL	COND	DIM/NOTE	YB	UNITS	ADJ PRICE	RCNLD

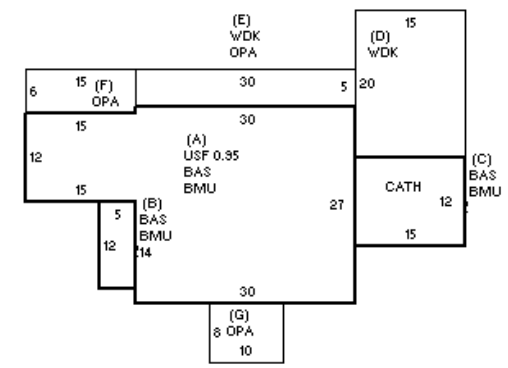

BLDG COMMENTS		
MEASURE	3/23/2023	NF
LIST	5/12/2023	EST
REVIEW	4/13/2023	EMZ
INTERIOR ESTIMATED PER PLANS 5/12/2023		

BUILDING	CD	ADJ	DESC	MEASURE	3/23/2023	NF
MODEL	1		RESIDENTIAL			
STYLE	5	1.00	COLONIAL [100%]	LIST	5/12/2023	EST
QUALITY	G	1.55	GOOD [100%]	REVIEW	4/13/2023	EMZ
FRAME	1	1.00	WOOD FRAME [100%]			

YEAR BLT	1956	SIZE ADJ	1.000	ELEMENT	CD	DESCRIPTION	ADJ	S	BAT	T	DESCRIPTION	UNITS	YB	ADJ PRICE	RCN	TOTAL RCN	1,018,426
NET AREA	2,171	DETAIL ADJ	1.030	FOUNDATION	4	FLR & WALL	1.00	+	BMU	N	BSMT UNFINISHED	1,230		107.34	132,029	CONDITION ELEM	CD
\$NLA(RCN)	\$469	OVERALL	1.000	EXT. COVER	1	WOOD SHINGLE	1.00	+	BAS	L	BAS AREA	1,230	1956	385.32	473,948	EXTERIOR	V
CAPACITY			UNITS	ADJ	ROOF SHAPE	6	SALTBOX	1.00	A	USF	L	UP-STRY FIN	941	326.96	307,669	INTERIOR	V
STORIES	1.95	1.00	ROOF COVER	1	ASPH/CMP SHIN	1.00	+	WDK	N	WOOD DECK	450		90.52	40,734	KITCHEN	V	
ROOMS	6	1.00	FLOOR COVER	12	HARDWD/SOFTWD	1.00	+	OPA	N	OPEN PORCH	320		117.96	37,746	BATHS	V	
BEDROOMS	3	1.00	INT. FINISH	2	DRYWALL	1.00		F21	O	FPL 2S 1OP	1		16,082.80	16,083	BATHS	V	
FULL BATHS	2	1.00	HEATING/COOL	9	WARM/COOL AIR	1.03									HEAT	U	
1/2 BATHS	1	1.00	FUEL SOURCE	2	GAS	1.00									ELECT	U	
FIXTURES	8	\$10,218															
UNITS	1	1.00															
																EFF.YR/AGE	2012 / 10
																COND	10 10 %
																FUNC	40 UC
																ECON	0
																DEPR	50 % GD 50
																RCNLD	\$509,200

