

Key: 5013

Town of CHATHAM - Fiscal Year 2024

9/7/2023 9:38 am SEQ #: 5.452

LEGAL

LAND

DETACHED

BUILDING

CURRENT OWNER				PARCEL ID				LOCATION			
SKTS REALTY TRUST CAHALY SCOTT D & KERRY A TRSTES 15 OAKLAWN RD SUMMIT, NJ 07901				4C-40-SM19				26 PORT VIEW RD			
TRANSFER HISTORY				DOS	T	SALE PRICE	BK-PG (Cert)				
SKTS REALTY TRUST				05/14/2018	QS	551,000	31263-35				
MARY B MUMFORD 2015 LIVIN				06/24/2016	R	1	29753-66				
MUMFORD MARY B				05/24/2016	A	1	29673-133				

CLASS	CLASS%	DESCRIPTION			BN ID	BN	CARD	
1010	100	SINGLE FAMILY				1	1 of 1	
PMT NO	PMT DT	TY	DESC	AMOUNT	INSP	BY	1st	%
19-435	06/13/2019	12	INSULATION	3,500	02/24/2020	TCK	100	100
1992225	03/09/2009	50	Meas & List			RRC	100	100
92-438	11/20/1992	99	n/a				100	100
		9	Foundation	5,000			100	100

CD	T	AC/SF/UN	Nbhd	Inf1	Inf2	ADJ BASE	SAF	Inf3	Lpi	VC	CREDIT AMT	ADJ VALUE
100	S	10,500	SC	1.00	1.00	733,000	3.07	1.00	1.00	R08	2.00	542,780

TOTAL	10,500 SF	ZONING	R20	FRNT	105	ASSESSED	CURRENT	PREVIOUS
Nbhd	SOUTH CHATHAM	NOTE DEEDED RIGHTS TO METTERS BEACH	LAND	542,800	452,300			
Inf1	100		BUILDING	470,500	401,700			
Inf2	100		DETACHED	600	600			
			OTHER	0	0			
TOTAL			1,013,900	854,600				

TY	QUAL	COND	DIM/NOTE	YB	UNITS	ADJ PRICE	RCNLD	PHOTO
SHF	A	1.00	20 0.80 6X8		48	16.25	600	02/22/2022



BLDG COMMENTS
CATHEDRAL CEILINGS EXPOSED BEAMS

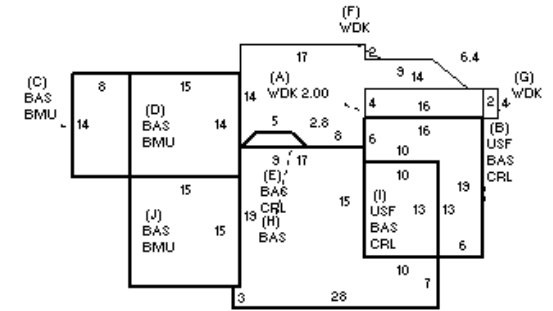

BUILDING	CD	ADJ	DESC	MEASURE	2/22/2022	TCK
MODEL	1		RESIDENTIAL	LIST	2/22/2022	EST
STYLE	8	0.95	CONTEMPORARY [100%]	REVIEW	3/3/2022	EMZ
QUALITY	+	1.20	PLUS AVE [100%]			
FRAME	1	1.00	WOOD FRAME [100%]			

YEAR BLT	1955	SIZE ADJ	1.000	ELEMENT	CD	DESCRIPTION	ADJ	S	BAT	T	DESCRIPTION	UNITS	YB	ADJ PRICE	RCN	TOTAL RCN	580,854	
NET AREA	1,616	DETAIL ADJ	0.978	FOUNDATION	4	FLR & WALL	1.00	+	WDK	N	WOOD DECK	406		70.08	28,452	CONDITION ELEM	CD	
\$NLA(RCN)	\$359	OVERALL	1.000	EXT. COVER	1	WOOD SHINGLE	1.00	+	CRL	N	CRAWL SPACE	751		24.47	18,376	EXTERIOR	A	
CAPACITY			UNITS	ADJ	ROOF SHAPE	1	GABLE	1.00	+	BAS	L	BAS AREA	496	1992	298.94	148,276	INTERIOR	G
STORIES	2	1.00	ROOF COVER	1	ASPH/CMP SHIN	1.00	1.00	B	USF	L	UP-STRY FIN	174	1992	253.66	44,137	KITCHEN	G	
ROOMS	4	1.00	FLOOR COVER	2	SOFTWOOD	1.00	1.00	+	BMU	N	BSMT UNFINISHED	547		82.27	45,000	BATHS	A	
BEDROOMS	2	1.00	INT. FINISH	2	DRYWALL	1.00	1.00	+	BAS	L	BAS AREA	816	1955	298.94	243,936	HEAT	U	
FULL BATHS	2	1.00	HEATING/COOL	9	WARM/COOL AIR	1.03	1.03	I	USF	L	UP-STRY FIN	130	1955	253.66	32,976	ELECT	U	
1/2 BATHS	0	1.00	FUEL SOURCE	2	GAS	1.00	1.00		BMG	O	BSMT GARAGE	1		3,324.00	3,324			
FIXTURES	6	\$5,633							F11	O	FPL 1S 1OP	1		8,972.40	8,972			
UNITS	1	1.00							ODS	O	OUT DOOR SHWR-A	1		1,772.40	1,772			

EFF.YR/AGE	2003 / 19
COND	19 19%
FUNC	0
ECON	0
DEPR	19 % GD 81
RCNLD	\$470,500