

Key: 5044

Town of CHATHAM - Fiscal Year 2024

9/7/2023 9:38 am SEQ #: 5.486

LEGAL

LAND

DETACHED

BUILDING

Table with columns: CURRENT OWNER, PARCEL ID, LOCATION, TRANSFER HISTORY, DOS, T, SALE PRICE, BK-PG (Cert). Includes owner name FERNE M PASTERNAK QPRT TR and parcel details.

Table with columns: CLASS, CLASS%, DESCRIPTION, BN ID, BN, CARD. Includes details for PMT NO, PMT DT, TY, DESC, AMOUNT, INSP, BY, 1st, %.

Table with columns: TOTAL, AC/SF/UN, ZONING, R20, FRNT, 90, ASSESSED, CURRENT, PREVIOUS. Includes assessed values for LAND, BUILDING, DETACHED, OTHER.

Table with columns: TY, QUAL, COND, DIM/NOTE, YB, UNITS, ADJ PRICE, RCNLD. Includes property characteristics like SHF, HTB, DIM/NOTE, YB, UNITS.

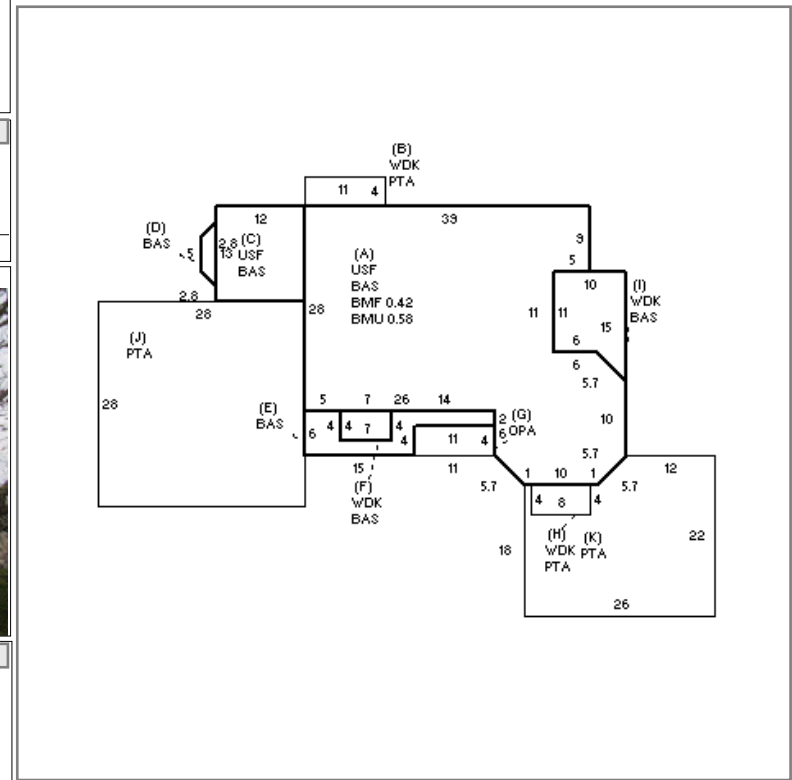

Table with columns: BUILDING, CD, ADJ, DESC, MEASURE, 12/10/2021, TCK. Includes building details like MODEL, STYLE, QUALITY, FRAME.

Table with columns: BLDG COMMENTS. Includes text: BMF=FAM RM, INFO @ DOOR 12/10/2021.

Large summary table with columns: YEAR BLT, SIZE ADJ, ELEMENT, CD, DESCRIPTION, ADJ, S, BAT, T, DESCRIPTION, UNITS, YB, ADJ PRICE, RCN, TOTAL RCN, CONDITION ELEM, CD. Includes capacity information and a detailed list of building elements and their costs.