

Key: 505

Town of CHATHAM - Fiscal Year 2024

9/7/2023 9:38 am SEQ #: 580

LEGAL

LAND

CURRENT OWNER				PARCEL ID				LOCATION			
KILTY KURT & JANINE 155 SEARS RD CHATHAM, MA 02633				11A-8A-T1				155 SEARS RD			
TRANSFER HISTORY				DOS	T	SALE PRICE	BK-PG (Cert)				
KILTY KURT & JANINE				02/21/2002	A	1	14840-216				
CHATHAM REALTY TRUST				07/31/1992	A	1	8141-133				
N/A				01/01/1979	N	72,500	2849-185				

CLASS	CLASS%	DESCRIPTION			BN ID	BN	CARD	
1010	100	SINGLE FAMILY				1	1 of 1	
PMT NO	PMT DT	TY	DESC	AMOUNT	INSP	BY	1st	%
21-372	04/27/2021	3	Renovations	180,000	03/21/2023	NF	100	100
	04/06/2012	51	Meas		04/06/2012	MR	100	100
	04/06/2012	61	Inspect/Revi		04/06/2012	MR	100	100
12-074	02/13/2012	2	Additions	60,000	05/05/2015	MW	100	100
	01/25/2011	50	Meas & List			CE	100	100

CD	T	AC/SF/UN	Nbhd	Inf1	Inf2	ADJ BASE	SAF	Inf3	Lpi	VC	CREDIT AMT	ADJ VALUE
100	S	40,000	CH	1.00	100	1,466,000	1.00	100	1.00	R11	4.00	1,346,190
300	A	0.005	CH	1.00	100	76,800	1.00	100	1.00	R11	4.00	380

TOTAL	40,200 SF	ZONING	R40	FRNT	0	ASSESSED	CURRENT	PREVIOUS
Nbhd	CHATHAM	N O T E	No Vw			LAND	1,346,600	1,122,100
Inf1	100		BUILDING	1,012,200	899,200			
Inf2	100		DETACHED	0	0			
			OTHER	0	0			
			TOTAL	2,358,800	2,021,300			

TY	QUAL	COND	DIM/NOTE	YB	UNITS	ADJ PRICE	RCNLD

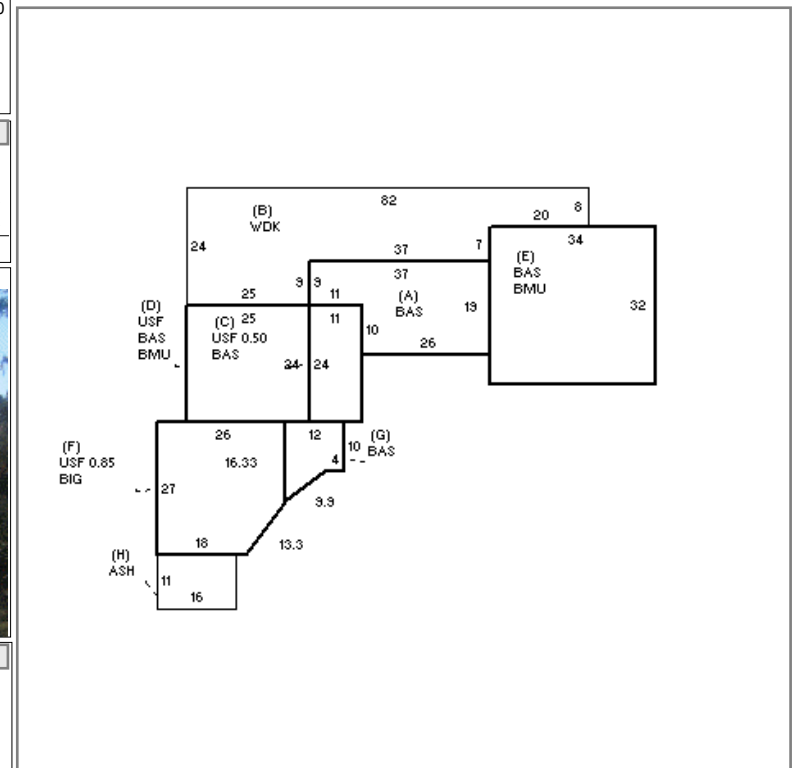

BUILDING	CD	ADJ	DESC	MEASURE		
MODEL	1		RESIDENTIAL	LIST	4/12/2023	EMZ
STYLE	4	1.00	CAPE [100%]			
QUALITY	A	1.03	AVERAGE [86%]			
FRAME	1	1.00	WOOD FRAME [100%]			

BLDG COMMENTS
GARAGE WITH STUDIO ABOVE

DETACHED

BUILDING

YEAR BLT	1965	SIZE ADJ	1.000	ELEMENT	CD	DESCRIPTION	ADJ	S	BAT	T	DESCRIPTION	UNITS	YB	ADJ PRICE	RCN	TOTAL RCN	1,204,971	
NET AREA	3,980	DETAIL ADJ	1.060	FOUNDATION	4	FLR & WALL	1.00	+	BAS	L	BAS AREA	1,600	1965	243.21	389,141			
\$NLA(RCN)	\$303	OVERALL	1.000	EXT. COVER	1	WOOD SHINGLE	1.00	B	WDK	N	WOOD DECK	1,315		60.04	78,946			
				ROOF SHAPE	1	GABLE	1.00	C	USF	L	UP-STRY FIN	132	1965	206.37	27,241	EXTERIOR	G	
				ROOF COVER	2	WOOD SHIN	1.01	+	BMU	N	BSMT UNFINISHED	1,688		67.40	113,770	INTERIOR	G	
				FLOOR COVER	3	W/W CARPET	1.00	D	USF	L	UP-STRY FIN	600	2021	206.37	123,825	KITCHEN	A	
				INT. FINISH	2	DRYWALL	1.00	E	BAS	L	BAS AREA	1,088	2010	243.21	264,617	BATHS	A	
				HEATING/COOL	11	HT-WT/COOL AIR	1.05	F	BIG	N	BUILT-IN GARAGE	659		78.35	51,630	HEAT	A	
				FUEL SOURCE	2	GAS	1.00	F	USF	L	UP-STRY FIN	560	2012	206.37	115,570	ELECT	A	
									H	ASH	N	ATT SHED	176		62.30	10,965		
										F21	O	FPL 2S 1OP	1		10,666.50	10,667		
										GEN	O	GENERATOR	1		0.00			
										GFP	O	GAS LOG/FP/E FP	1		6,396.20	6,396		

CONDITION ELEM	CD
EXTERIOR	G
INTERIOR	G
KITCHEN	A
BATHS	A
HEAT	A
ELECT	A

EFF.YR/AGE	2006 / 16
COND	16 16 %
FUNC	0
ECON	0
DEPR	16 % GD 84

RCNLD	\$1,012,200
-------	-------------