

Key: 5442

Town of CHATHAM - Fiscal Year 2024

9/7/2023 9:38 am SEQ #: 5.896

LEGALS

CURRENT OWNER				PARCEL ID				LOCATION			
BARBARA D RYBECK 2004 INSURANCE TRUST c/o DEAN RYBECK 262 TRYON ST S GLASTONBURY, CT 06073				5C-32-J5				22 TAYLORS POND RD			
TRANSFER HISTORY				DOS	T	SALE PRICE	BK-PG (Cert)				
BARBARA D RYBECK 2004 INS				01/13/2011	A	1	25180-102				
BARBARA D RYBECK QPRT				11/14/2000	A	100	13361-277				
RYBECK JAMES				09/03/1998	A	1	11679-26				

CLASS	CLASS%	DESCRIPTION			BN ID	BN	CARD	
1010	100	SINGLE FAMILY				1	1 of 1	
PMT NO	PMT DT	TY	DESC	AMOUNT	INSP	BY	1st	%
01-526	03/12/2009	50	Meas & List			RRC	100	100
97-263	10/26/2001	3	Renovations	10,000			100	100
	07/01/1997	3	Renovations	46,250			100	100

LAND

CD	T	AC/SF/UN	Nbhd	Inf1	Inf2	ADJ BASE	SAF	Inf3	Lpi	VC	CREDIT AMT	ADJ VALUE
100	S	11,742	SC	1.00	100	1.00	100	1.00	CV1	1.75		482,620

TOTAL	11,720 SF	ZONING	R20	FRNT	100	ASSESSED	CURRENT	PREVIOUS
Nbhd	SOUTH CHATHAM	NOTE				LAND	482,600	402,200
Inf1	100		BUILDING	639,300	590,000			
Inf2	100		DETACHED	0	0			
			OTHER	0	0			
						<b>TOTAL</b>	<b>1,121,900</b>	<b>992,200</b>

DETACHED

TY	QUAL	COND	DIM/NOTE	YB	UNITS	ADJ PRICE	RCNLD

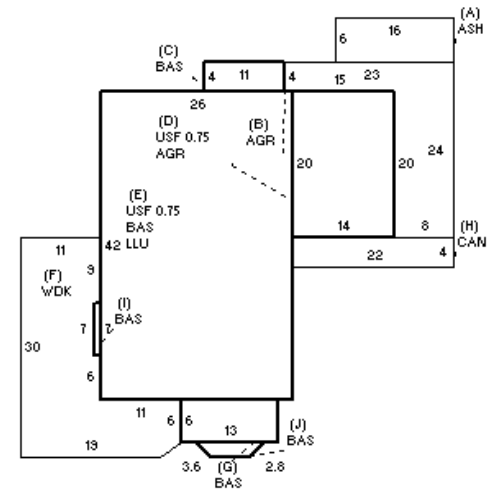

BLDG COMMENTS

BUILDING

BUILDING	CD	ADJ	DESC	MEASURE	2/22/2022	TCK
MODEL	1		RESIDENTIAL	LIST	2/22/2022	EST
STYLE	4	1.00	CAPE [100%]	REVIEW	3/3/2022	EMZ
QUALITY	+	1.20	PLUS AVE [100%]			
FRAME	1	1.00	WOOD FRAME [100%]			

YEAR BLT	1972	SIZE ADJ	1.000	ELEMENT	CD	DESCRIPTION	ADJ
NET AREA	2,264	DETAIL ADJ	1.060	FOUNDATION	4	FLR & WALL	1.00
\$NLA(RCN)	\$398	OVERALL	1.000	EXT. COVER	1	WOOD SHINGLE	1.00
				ROOF SHAPE	1	GABLE	1.00
				ROOF COVER	2	WOOD SHIN	1.01
				FLOOR COVER	1	HARDWOOD	1.00
				INT. FINISH	2	DRYWALL	1.00
				HEATING/COOL	11	HT-WT/COOL AIR	1.05
				FUEL SOURCE	2	GAS	1.00

S	BAT	T	DESCRIPTION	UNITS	YB	ADJ PRICE	RCN
A	ASH	N	ATT SHED	96		72.73	6,982
+	AGR	N	ATTACHED GARAGE	532		93.33	49,654
+	BAS	L	BAS AREA	1,235	1972	289.04	356,964
+	USF	L	UP-STRY FIN	1,029	1972	245.26	252,372
E	LLU	N	LOWER LEVEL UN	1,092		162.86	177,840
F	WDK	N	WOOD DECK	408		70.08	28,592
H	CAN	N	CANOPY	88		52.32	4,604
	F21	O	FPL 2S 10P	1		12,451.20	12,451
	ODS	O	OUT DOOR SHWR-A	1		1,772.40	1,772

TOTAL RCN	900,390	CONDITION ELEM	CD
EXTERIOR			A
INTERIOR			A
KITCHEN			A
BATHS			G
HEAT			A
ELECT			A
EFF.YR/AGE	1975 / 47		
COND	29	29 %	
FUNC	0		
ECON	0		
DEPR	29	% GD	71
RCNLD			\$639,300