

Key: 5543

Town of CHATHAM - Fiscal Year 2024

9/7/2023 9:38 am SEQ #: 5.999

LEGAL

LAND

DETACHED

BUILDING

CURRENT OWNER				PARCEL ID				LOCATION				
BOAS NICHOLAS J & LIANNE S 59 SHANNON LN CHATHAM, MA 02633				5D-52H-H23				59 SHANNON LN				
TRANSFER HISTORY				DOS	T	SALE PRICE	BK-PG (Cert)					
BOAS NICHOLAS J & LIANNE				08/04/1997	S	39,900	10885-97					
CAPE COD FIVE SAVINGS				02/13/1997	L	1	10609-93					
HENDERSON, MARTIN				01/12/1990	QS	75,000	7023-302					
CD	T	AC/SF/UN	Nbhd	Inf1	Inf2	ADJ BASE	SAF	Inf3	Lpi	VC	CREDIT AMT	ADJ VALUE
100	S	20,900	SC	1.00	90 0.90	100 1.00	527,760	1.71	100 1.00	R05 1.60		433,280

CLASS	CLASS%	DESCRIPTION			BN ID	BN	CARD	
1010	100	SINGLE FAMILY				1	1 of 1	
PMT NO	PMT DT	TY	DESC	AMOUNT	INSP	BY	1st	%
09-304	06/06/2019	3	Renovations	46,500	06/06/2019	APK	100	100
	01/26/2010	51	Meas		CE	100	100	
	08/20/2009	3	Renovations		RRC	100	100	
	02/04/2006	50	Meas & List			100	100	
000000936	03/15/2005	1	New Construc	260,000			100	100

TOTAL	20,900 SF	ZONING	R20	FRNT	0	ASSESSED	CURRENT	PREVIOUS
Nbhd	SOUTH CHATHAM	NOTE INFL1=TOPO	LAND		433,300	361,100		
Inf1	90		BUILDING		454,300	418,200		
Inf2	100		DETACHED		0	0		
			OTHER		0	0		
TOTAL				887,600		779,300		

TY	QUAL	COND	DIM/NOTE	YB	UNITS	ADJ PRICE	RCNLD



BLDG COMMENTS  
LLF=2RMS,1MECH,1STG, 1FBATH (PER PLANS-APK)

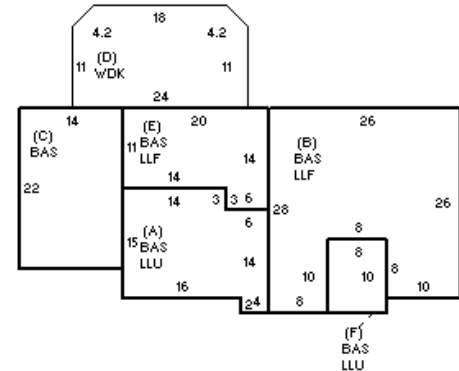

BUILDING	CD	ADJ	DESC	MEASURE	11/9/2021	TCK
MODEL	1		RESIDENTIAL	LIST	11/9/2021	EST
STYLE	1	0.85	RANCH [100%]	REVIEW	12/17/2021	MR
QUALITY	A	1.00	AVERAGE [100%]			
FRAME	1	1.00	WOOD FRAME [100%]			

YEAR BLT	2005	SIZE ADJ	1.000	ELEMENT	CD	DESCRIPTION	ADJ	S	BAT	T	DESCRIPTION	UNITS	YB	ADJ PRICE	RCN	TOTAL RCN	516,221		
NET AREA	1,544	DETAIL ADJ	0.850	FOUNDATION	4	FLR & WALL	1.00	+	LLU	N	LOWER LEVEL UN	370		111.36	41,205	CONDITION ELEM CD			
\$NLA(RCN)	\$334	OVERALL	1.000	EXT. COVER	1	WOOD SHINGLE	1.00	+	BAS	L	BAS AREA	1,236	2005	197.65	244,294	EXTERIOR	G		
CAPACITY			UNITS	ADJ	ROOF SHAPE	1	GABLE	1.00	+	LLF	N	LOWER LEVEL FIN	866	145.45	125,964	INTERIOR	G		
STORIES	1	1.00	ROOF COVER	1	ASPH/CMP SHIN	1.00	C	BAS	L	BAS AREA	308	2009	197.65	60,876	KITCHEN	A			
ROOMS	6	1.00	FLOOR COVER	16	HARDWD/OTHER	1.00	D	WDK	N	WOOD DECK	327		58.40	19,097	BATHS	A			
BEDROOMS	2	1.00	INT. FINISH	2	DRYWALL	1.00		GFP	O	GAS LOG/FP/E FP	3		6,221.67	18,665	HEAT	A			
FULL BATHS	3	1.00	HEATING/COOL	2	HOT WATER	1.00									ELECT	A			
1/2 BATHS	0	1.00	FUEL SOURCE	2	GAS	1.00													
FIXTURES	9	\$6,120																	
UNITS	1	1.00																	
																EFF.YR/AGE	2010 / 12		
																COND	12 12 %		
																FUNC	0		
																ECON	0		
																DEPR	12	% GD	88
																RCNLD	\$454,300		