

Key: 57

Town of CHATHAM - Fiscal Year 2024

9/7/2023 9:38 am SEQ #: 65

LEGAL

LAND

DETACHED

BUILDING

CURRENT OWNER				PARCEL ID				LOCATION			
ANTHONY NICOS J & HELEN PO BOX 497 N SALEM, NY 10560-0497				10C-12-B46				75 BARN HILL LN			
TRANSFER HISTORY				DOS	T	SALE PRICE	BK-PG (Cert)				
ANTHONY NICOS J & HELEN				02/21/1984	QS	110,000	4020-109				

CLASS	CLASS%	DESCRIPTION			BN ID	BN	CARD	
1010	100	SINGLE FAMILY				1	1 of 1	
PMT NO	PMT DT	TY	DESC	AMOUNT	INSP	BY	1st	%
21-548	06/08/2021	10	Reroof	11,000	04/28/2022	NF	100	100
	03/06/2005	50	Meas & List			RRC	100	100
000000551	08/17/2004	99	n/a	1,500			100	100
P2004415	08/02/2004	99	n/a	1,725			100	100
03-407	09/05/2003	99	n/a	10,000			100	100

CD	T	AC/SF/UN	Nbhd	Inf1	Inf2	ADJ BASE	SAF	Inf3	Lpi	VC	CREDIT AMT	ADJ VALUE
100	S	11,500	WC	1.00	100	1.00	100	1.00	R05	1.50		412,430

TOTAL	11,500 SF	ZONING	R20	FRNT	100	ASSESSED	CURRENT	PREVIOUS
Nbhd	WEST CHATHAM	NOTE				LAND	412,400	343,700
Inf1	100		BUILDING	694,000	639,200			
Inf2	100		DETACHED	0	0			
			OTHER	0	0			
TOTAL			1,106,400	982,900				

TY	QUAL	COND	DIM/NOTE	YB	UNITS	ADJ PRICE	RCNLD

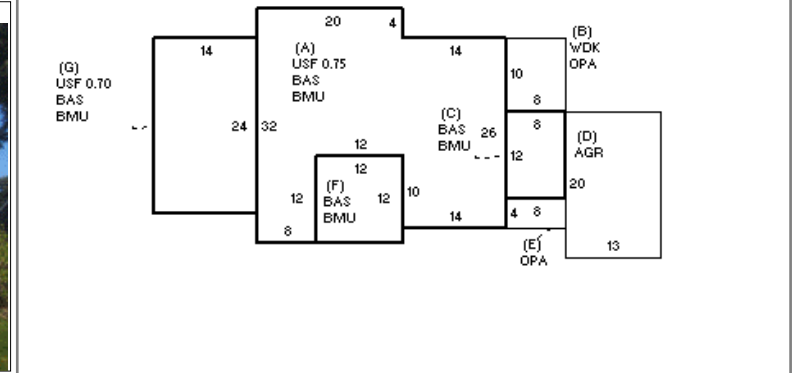

BUILDING	CD	ADJ	DESC	MEASURE		
MODEL	1		RESIDENTIAL	LIST REVIEW	5/11/2022	MR
STYLE	4	1.00	CAPE [100%]			
QUALITY	+	1.20	PLUS AVE [100%]			
FRAME	1	1.00	WOOD FRAME [100%]			

BLDG COMMENTS	

YEAR BLT	2004	SIZE ADJ	1.000	ELEMENT	CD	DESCRIPTION	ADJ	S	BAT	T	DESCRIPTION	UNITS	YB	ADJ PRICE	RCN	TOTAL RCN	826,192		
NET AREA	2,316	DETAIL ADJ	1.030	FOUNDATION	4	FLR & WALL	1.00	+	BMU	N	BSMT UNFINISHED	1,436		80.76	115,976	CONDITION ELEM	CD		
\$NLA(RCN)	\$357	OVERALL	1.000	EXT. COVER	1	WOOD SHINGLE	1.00	+	BAS	L	BAS AREA	1,436	2004	295.20	423,905	EXTERIOR			
				ROOF SHAPE	6	SALTBOX	1.00	+	USF	L	UP-STRY FIN	880	2004	250.49	220,427	INTERIOR			
				ROOF COVER	1	ASPH/CMP SHIN	1.00	+	OPA	N	OPEN PORCH	112		91.32	10,228	KITCHEN			
				FLOOR COVER	16	HARDWD/OTHER	1.00	B	WDK	N	WOOD DECK	80		70.08	5,606	BATHS			
				INT. FINISH	2	DRYWALL	1.00	D	AGR	N	ATTACHED GARAGE	260		103.56	26,927	HEAT			
				HEATING/COOL	9	WARM/COOL AIR	1.03	F21	O	FPL 2S 1OP	1		12,451.20	12,451	ELECT				
				FUEL SOURCE	2	GAS	1.00	ODS	O	OUT DOOR SHWR-A	1		1,772.40	1,772					
																		EFF.YR/AGE	2006 / 16
																		COND	16 16 %
																		FUNC	0
																		ECON	0
																		DEPR	16 % GD 84
																		RCNLD	\$694,000