

Key: 5768

Town of CHATHAM - Fiscal Year 2024

9/7/2023 9:38 am SEQ #: 6.233

LEGALS AND

Table with columns: CURRENT OWNER, PARCEL ID, LOCATION, TRANSFER HISTORY, DOS, T, SALE PRICE, BK-PG (Cert), CD, T, AC/SF/UN, Nbhd, Inf1, Inf2, ADJ BASE, SAF, Inf3, Lpi, VC, CREDIT AMT, ADJ VALUE.

Table with columns: CLASS, CLASS%, DESCRIPTION, BN ID, BN, CARD, PMT NO, PMT DT, TY, DESC, AMOUNT, INSP, BY, 1st, %.

Table with columns: TOTAL, ZONING, R20, FRNT, 105, ASSESSED, CURRENT, PREVIOUS, Nbhd, SOUTH CHATHAM, Inf1, 100, Inf2, 100.

Table with columns: TY, QUAL, COND, DIM/NOTE, YB, UNITS, ADJ PRICE, RCNLD, SHF, A, 1.00, 30, 0.70, 1982, 120, 13.29, 1,100.

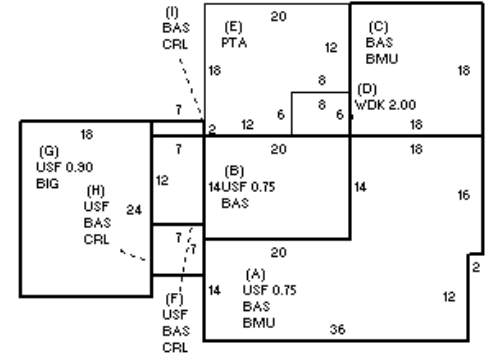

Table with columns: BUILDING, CD, ADJ, DESC, MEASURE, 11/15/2021, TCK, MODEL, STYLE, QUALITY, FRAME, LIST, REVIEW.

BLDG COMMENTS: INFO @ DOOR 11/15/21

DETACHED

BUILDING

Main table with columns: YEAR BLT, NET AREA, \$NLA(RCN), CAPACITY, UNITS, ADJ, ELEMENT, CD, DESCRIPTION, ADJ, S, BAT, T, DESCRIPTION, UNITS, YB, ADJ PRICE, RCN, TOTAL RCN, CONDITION ELEM, CD, EFF. YR/AGE, COND, FUNC, ECON, DEPR, RCNLD.