

Key: 5816

Town of CHATHAM - Fiscal Year 2024

9/7/2023 9:38 am SEQ #: 6.281

LEGAL

LAND

DETACHED

BUILDING

CURRENT OWNER				PARCEL ID				LOCATION			
COLOZZI FAMILY TRUST NOW COLOZZI JENNIEN 20 COUNTRY CLUB DR NEW YORK MILLS, NY 13413				6C-68-G128				83 DIANE DR			
TRANSFER HISTORY				DOS	T	SALE PRICE	BK-PG (Cert)				
COLOZZI JENNIEN				06/09/2023	A	300,000	35832-144				
COLOZZI FAMILY TRUST				09/02/2004	A	1	19000-111				
COLOZZI SALVATORE				06/14/1991	QS	132,000	7571-170				

CLASS	CLASS%	DESCRIPTION			BN ID	BN	CARD	
1010	100	SINGLE FAMILY				1	1 of 1	
PMT NO	PMT DT	TY	DESC	AMOUNT	INSP	BY	1st	%
P2002350	02/16/2009	50	Meas & List			RRC	100	100
94-269	04/01/2003	50	Meas & List			JB	100	100
1991056	08/02/2002	2	Additions	6,660			100	100
	08/01/1994	2	Additions	3,000			100	100
	05/09/1991	99	n/a				100	100

CD	T	AC/SF/UN	Nbhd	Inf1	Inf2	ADJ BASE	SAF	Inf3	Lpi	VC	CREDIT AMT	ADJ VALUE	
100	S	8,100	SC	1.00	1.00	1.00	1.00	916,250	3.84	100	1.00	R10 2.50	654,210

TOTAL	8,100 SF	ZONING	R20	FRNT	70	ASSESSED	CURRENT	PREVIOUS
Nbhd	SOUTH CHATHAM	NOTE				LAND	654,200	545,200
Inf1	100		BUILDING	360,200	327,800			
Inf2	100		DETACHED	400	400			
			OTHER	0	0			
						<b>TOTAL</b>	<b>1,014,800</b>	<b>873,400</b>

TY	QUAL	COND	DIM/NOTE	YB	UNITS	ADJ PRICE	RCNLD
SHF	A	1.00	50 0.50 6X8		48	16.25	400



BUILDING	CD	ADJ	DESC	MEASURE	11/17/2021	TCK
MODEL	1		RESIDENTIAL	LIST	11/17/2021	EST
STYLE	4	1.00	CAPE [100%]	REVIEW	12/22/2021	MR
QUALITY	+	1.20	PLUS AVE [100%]			
FRAME	1	1.00	WOOD FRAME [100%]			

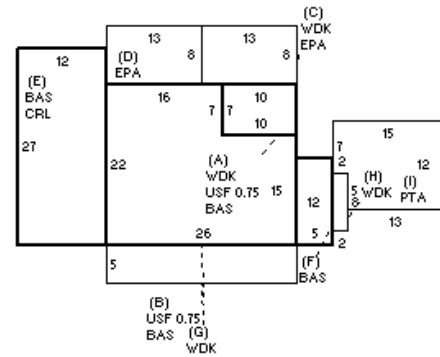

YEAR BLT	1952	SIZE ADJ	1.000	ELEMENT	CD	DESCRIPTION	ADJ	S	BAT	T	DESCRIPTION	UNITS	YB	ADJ PRICE	RCN	TOTAL RCN	507,364				
NET AREA	1,385	DETAIL ADJ	1.000	FOUNDATION	99	N/A	1.00	+	BAS	L	BAS AREA	572	1952	316.26	180,900	CONDITION ELEM	CD				
\$NLA(RCN)	\$366	OVERALL	1.000	EXT. COVER	1	WOOD SHINGLE	1.00	+	USF	L	UP-STRY FIN	429	1952	268.36	115,124	EXTERIOR	G				
				ROOF SHAPE	1	GABLE	1.00	+	EPA	N	ENCL PORCH	208		160.44	33,372	INTERIOR	G				
				ROOF COVER	1	ASPH/CMP SHIN	1.00	E	CRL	N	CRAWL SPACE	324		32.29	10,463	KITCHEN	A				
				FLOOR COVER	24	SOFTWD/ASPH TL	1.00	E	BAS	L	BAS AREA	324	1991	316.26	102,468	BATHS	A				
				INT. FINISH	2	DRYWALL	1.00	F	BAS	L	BAS AREA	60	1981	316.26	18,976	HEAT	A				
				HEATING/COOL	1	FORCED AIR	1.00	+	WDK	N	WOOD DECK	320		70.08	22,426	ELECT	A				
				FUEL SOURCE	2	GAS	1.00	I	PTA	N	PATIO/STOOP	170		21.48	3,652						
													F21	O	FPL 2S 1OP	1	12,451.20	12,451			
													ODS	O	OUT DOOR SHWR-A	1	1,772.40	1,772			
													EFF.YR/AGE		1975 / 47						
													COND	29	29%						
													FUNC	0							
													ECON	0							
													DEPR	29	% GD	71					
													RCNLD		\$360,200						