

Key: 5978

Town of CHATHAM - Fiscal Year 2024

9/7/2023 9:38 am SEQ #: 6.443

LEG  
AL  
LAND

CURRENT OWNER				PARCEL ID				LOCATION				
2079 MAIN LLC 2079 MAIN ST CHATHAM, MA 02633				6E-40-K1				2079 MAIN ST				
TRANSFER HISTORY				DOS	T	SALE PRICE	BK-PG (Cert)					
2079 MAIN LLC				07/01/2022	N	3,855,000	35225-199					
LAYN WALKER LLC				04/11/2014	C	1,850,000	28083-314					
WISEMAN RETREATS REALTY T				05/08/2001	QS	880,000	13810-333					
CD	T	AC/SF/UN	Nbhd	Inf1	Inf2	ADJ BASE	SAF	Inf3	Lpi	VC	CREDIT AMT	ADJ VALUE
103	S	61,855	CI	1.00	1.00	1.00	1.00	1.00	MS2	1.10		651,200

CLASS	CLASS%	DESCRIPTION			BN ID	BN	CARD	
3010	100	MOTELS				1	1 of 1	
PMT NO	PMT DT	TY	DESC	AMOUNT	INSP	BY	1st	%
21-950	10/19/2021	99	n/a					0 0
17-708	10/16/2017	3	Renovations	24,500	06/21/2018	PJK	100	100
16-779	11/23/2016	3	Renovations	41,350	06/26/2017	RJM	100	100
15-619	10/19/2015	10	Reroof	45,000				0 0
14-219	04/25/2014	3	Renovations	18,960	05/19/2015	MW	100	100

DE  
TA  
CH  
ED

TOTAL	1.420 Acres	ZONING	R20	FRNT	195	ASSESSED	CURRENT	PREVIOUS
Nbhd	COMMERCIAL	NOTE				LAND	651,200	592,000
Inf1	100		LAND	978,200	892,200			
Inf2	100		DETACHED	41,700	39,800			
			OTHER	0	0			
<b>TOTAL</b>						<b>1,671,100</b>	<b>1,524,000</b>	

PH  
OTO

TY	QUAL	COND	DIM/NOTE	YB	UNITS	ADJ PRICE	RCNLD
APV	A	1.00	70 0.30	1995	20,000	2.00	12,000
SHF	G	1.20	10 0.90	2005	160	14.76	2,100
IPV	G	1.20	30 0.70	2006	800	35.44	19,800
C06	A	1.00	10 0.90	2006	352	17.40	5,500
SN2	A	1.00	10 0.90		36	70.60	2,300

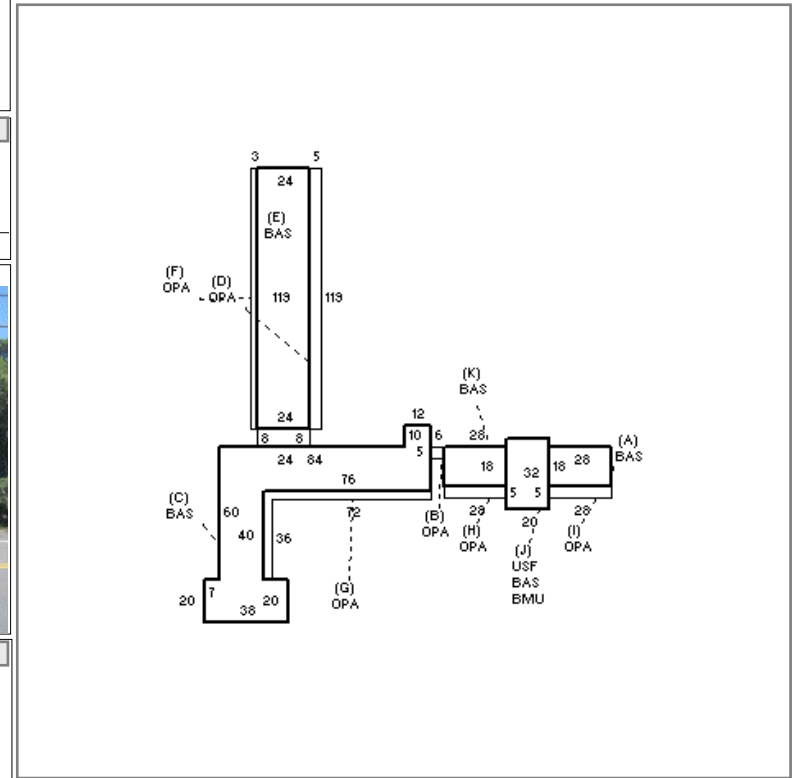

BL  
UD  
ING

BUILDING	CD	ADJ	DESC	MEASURE	LIST	REVIEW
MODEL	5		CIM			
STYLE	43	1.25	MOTEL/HOTEL [100%]			
QUALITY	G	1.40	GOOD [100%]			
FRAME	1	1.00	WOOD FRAME [100%]			

BLDG COMMENTS  
CHATHAM SEAFARER MOTEL/7 EFFICIENCIES, 13  
SINGLE RMS, OWNERS QUARTERS=3BDRMS, FPL, 1  
UNIT FOR EMPLOYEE 1BDRM

YEAR BLT	1958	SIZE ADJ	1.000	ELEMENT	CD	DESCRIPTION	ADJ	S	BAT	T	DESCRIPTION	UNITS	YB	ADJ PRICE	RCN	TOTAL RCN	1,178,581
NET AREA	8,744	DETAIL ADJ	1.248	FOUNDATION	3	FOUND WALL	1.00	+	BAS	L	BASE AREA	8,104	1958	125.28	1,015,276		
\$NLA(RCN)	\$135	OVERALL	1.000	EXT. COVER	1	WOOD SHINGLE	1.00	+	OPA	N	OPEN PORCH	1,902		31.36	59,647		
				ROOF SHAPE	1	GABLE	1.00	J	BMU	N	BSMT UNF	640		28.30	18,112		
				ROOF COVER	1	ASPH/CMP SHIN	1.00	J	USF	L	UP-STRY FIN	640	1958	125.28	80,180		
				FLOOR COVER	34	CARPET/ASPH TL	1.00		PTA	N	PATIO	170		8.82	1,499		
				INT. FINISH	2	DRYWALL	1.00		F11	O	FPL 1S 1OP	1		3,867.00	3,867		
				HEATING/COOL	1	FORCED AIR	1.00										
				FUEL SOURCE	3	ELECTRIC	1.00										
																CONDITION ELEM	CD
																EXTERIOR	
																INTERIOR	
																CDN/APP	
																EFF.YR/AGE	2005 / 17
																COND	17 17 %
																FUNC	0
																ECON	0
																DEPR	17 % GD 83
																RCNLD	\$978,200