

Key: 6173

Town of CHATHAM - Fiscal Year 2024

9/7/2023 9:38 am SEQ #: 6.629

LEGAL

LAND

DETACHED

BUILDING

CURRENT OWNER				PARCEL ID				LOCATION			
TM HOLDINGS LLC 25 HIGHLAND PARK VLG STE 100-559 DALLAS, TX 75205				7A-19-S57				5 CABOT LN			
TRANSFER HISTORY				DOS	T	SALE PRICE	BK-PG (Cert)				
TM HOLDINGS LLC				05/23/2022	V	1,150,000	35137-71				
TM HOLDINGS LLC				08/25/2011	A	320,000	25640-179				
NEIL&ELIZABETH EISNER FAM				04/08/2009	A	10	23595-326				

CLASS	CLASS%	DESCRIPTION			BN ID	BN	CARD	
1010	100	SINGLE FAMILY				1	1 of 1	
PMT NO	PMT DT	TY	DESC	AMOUNT	INSP	BY	1st	%
21-189	06/21/2022	98	SALES QUESTI				100	100
	03/03/2021	3	Renovations	9,000	04/22/2022	NF	100	100
	02/18/2009	50	Meas & List			RRC	100	100
95-150	04/01/1995	14	DECK	6,500			100	100
1994105	05/10/1994	99	n/a				100	100

CD	T	AC/SF/UN	Nbhd	Inf1	Inf2	ADJ BASE	SAF	Inf3	Lpi	VC	CREDIT AMT	ADJ VALUE
100	S	15,060	WC	1.00	1.00	2,748,750	2.26	1.00	V10	7.50		2,145,450

TOTAL	15,060 SF	ZONING	R20	FRNT	133	ASSESSED	CURRENT	PREVIOUS
Nbhd	WEST CHATHAM	NOTE				LAND	2,145,500	1,787,800
Inf1	100		BUILDING	334,300	308,500			
Inf2	100		DETACHED	0	0			
			OTHER	0	0			
						<b>TOTAL</b>	<b>2,479,800</b>	<b>2,096,300</b>

TY	QUAL	COND	DIM/NOTE	YB	UNITS	ADJ PRICE	RCNLD	PHOTO	04/22/2022
									

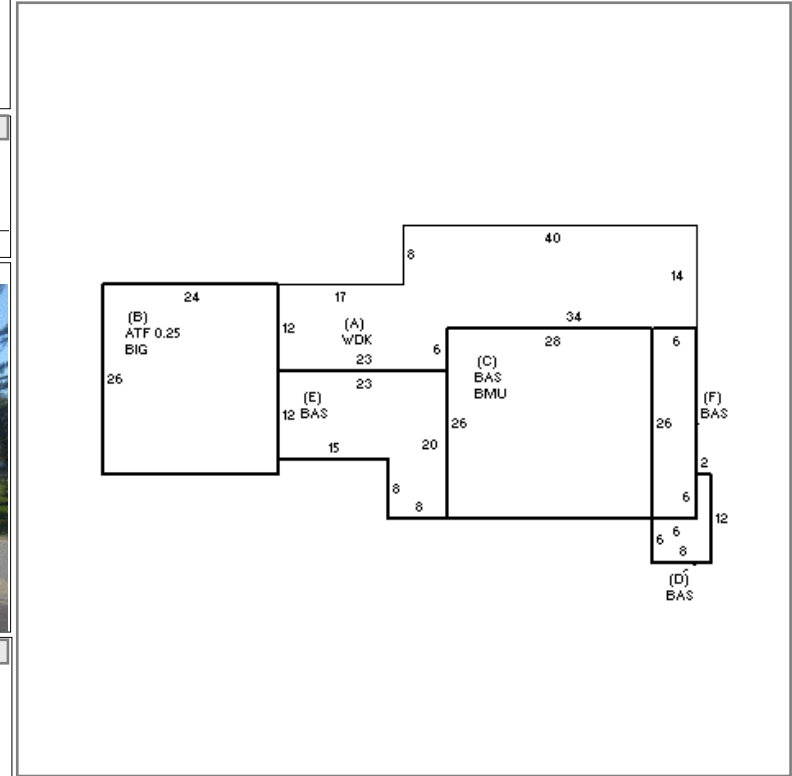

BUILDING	CD	ADJ	DESC	MEASURE		
MODEL	1		RESIDENTIAL	LIST		
STYLE	1	0.85	RANCH [100%]	REVIEW	5/10/2022	MR
QUALITY	A	1.00	AVERAGE [100%]			
FRAME	1	1.00	WOOD FRAME [100%]			

BLDG COMMENTS	YEAR BLT	1952	SIZE ADJ	1.000	ELEMENT	CD	DESCRIPTION	ADJ	S	BAT	T	DESCRIPTION	UNITS	YB	ADJ PRICE	RCN	TOTAL RCN	470,783	
	NET AREA	1,440	DETAIL ADJ	0.850	FOUNDATION	4	FLR & WALL	1.00	A	WDK	N	WOOD DECK	800		58.40	46,720	CONDITION ELEM	CD	
	\$NLA(RCN)	\$327	OVERALL	1.000	EXT. COVER	1	WOOD SHINGLE	1.00	B	BIG	N	BUILT-IN GARAGE	624		76.56	47,773	EXTERIOR	A	
					ROOF SHAPE	1	GABLE	1.00	B	ATF	L	FINISHED ATTIC	156	1970	133.59	20,840	INTERIOR	G	
					ROOF COVER	1	ASPH/CMP SHIN	1.00	C	BMU	N	BSMT UNFINISHED	728		78.65	57,256	KITCHEN	G	
					FLOOR COVER	23	SOFTWD/CARPET	1.00	+	BAS	L	BAS AREA	216	1975	222.09	47,971	BATHS	G	
					INT. FINISH	2	DRYWALL	1.00	+	BAS	L	BAS AREA	1,068	1952	222.09	237,189	HEAT	A	
					HEATING/COOL	5	ELECTRIC BB	1.00	F11	O	FPL 1S 1OP	1		7,477.00	7,477	ELECT	A		
					FUEL SOURCE	3	ELECTRIC	1.00	ODS	O	OUT DOOR SHWR-A	1		1,477.00	1,477				
																		EFF.YR/AGE	1975 / 47
																		COND	29 29 %
																		FUNC	0
																		ECON	0
																		DEPR	29 % GD 71
																		RCNLD	\$334,300