

Key: 623

Town of CHATHAM - Fiscal Year 2024

9/7/2023 9:38 am SEQ #: 711

LEGAL

LAND

CURRENT OWNER				PARCEL ID				LOCATION				
SHEERAN JOHN P & SHEILA H 67 UNCLE ALBERTS DR CHATHAM, MA 02633				11E-23A-R5				67 UNCLE ALBERTS DR				
TRANSFER HISTORY				DOS	T	SALE PRICE	BK-PG (Cert)					
SHEERAN JOHN P & SHEILA H				02/19/2015	QS	2,350,000	28690-190					
EASTWARD COMPANIES BUSINE				12/30/2013	P	525,000	27912-279					
BYRNE SIMONE C & PRESTON				09/29/2004	O	820,000	19082-175					
CD	T	AC/SF/UN	Nbhd	Inf1	Inf2	ADJ BASE	SAF	Inf3	Lpi	VC	CREDIT AMT	ADJ VALUE
100	S	40,000	WC	1.00	100	842,950	1.00	100	1.00	VW3	2.30	774,060
300	A	1.148	WC	1.00	100	44,160	1.00	100	1.00	VW3	2.30	50,700

CLASS	CLASS%	DESCRIPTION			BN ID	BN	CARD	
1010	100	SINGLE FAMILY				1	1 of 1	
PMT NO	PMT DT	TY	DESC	AMOUNT	INSP	BY	1st	%
15-066	02/11/2015	2	Additions	50,000	06/21/2016	WFF	100	100
14-115	03/06/2014	1	New Construc	750,000	06/21/2016	WFF	100	100
	03/01/2007	50	Meas & List			RRC	100	100
	03/16/2006	50	Meas & List			RRC	100	100
05-369	08/22/2005	99	n/a	170,000			100	100

TOTAL	2.066 Acres		ZONING	R40	FRNT	0	ASSESSED	CURRENT	PREVIOUS
Nbhd	WEST CHATHAM		N O T E	R20 Zoning Protection/88 Plan			LAND	824,800	687,300
Inf1	100			BUILDING	3,835,100	3,201,700			
Inf2	100			DETACHED	0	0			
				OTHER	0	0	TOTAL	4,659,900	3,889,000

TY	QUAL	COND	DIM/NOTE	YB	UNITS	ADJ PRICE	RCNLD

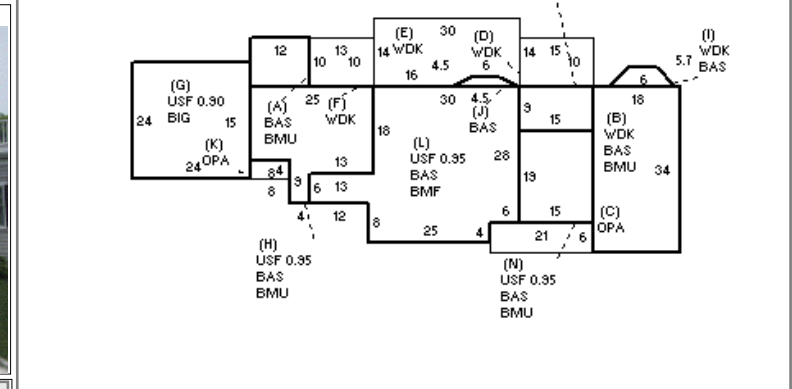

BUILDING	CD	ADJ	DESC	MEASURE	6/21/2016	WFF
MODEL	1		RESIDENTIAL	LIST	6/16/2017	APK
STYLE	19	1.30	NEW STYLE [100%]	REVIEW	6/16/2017	APK
QUALITY	V	2.35	VERY GOOD [100%]			
FRAME	1	1.00	WOOD FRAME [100%]			

BLDG COMMENTS
CATHEDRAL ENTRY

DETACHED

BUILDING

YEAR BLT	2014	SIZE ADJ	1.000	ELEMENT	CD	DESCRIPTION	ADJ	S	BAT	T	DESCRIPTION	UNITS	YB	ADJ PRICE	RCN	TOTAL RCN	4,168,604		
NET AREA	5,000	DETAIL ADJ	1.339	FOUNDATION	4	FLR & WALL	1.00	+	BMU	N	BSMT UNFINISHED	1,467		155.38	227,945	CONDITION ELEM	CD		
\$NLA(RCN)	\$834	OVERALL	1.000	EXT. COVER	1	WOOD SHINGLE	1.00	+	OPA	N	OPEN PORCH	158		178.84	28,256	EXTERIOR	A		
				ROOF SHAPE	3	GAMBREL	1.00	+	WDK	N	WOOD DECK	1,332		137.24	182,804	INTERIOR	A		
				ROOF COVER	4	WOOD SHAKES	1.00	G	BIG	N	BUILT-IN GARAGE	576		181.35	104,455	KITCHEN	A		
				FLOOR COVER	1	HARDWOOD	1.00	+	USF	L	UP-STRY FIN	2,316	2014	584.50	1,353,694	BATHS	A		
				INT. FINISH	2	DRYWALL	1.00	+	BAS	L	BAS AREA	2,684	2014	688.83	1,848,825	HEAT	A		
				HEATING/COOL	9	WARM/COOL AIR	1.03	L	BMF	N	BSMT FINISH-SEP	1,022		255.21	260,824	ELECT	A		
				FUEL SOURCE	2	GAS	1.00	M	CRL	N	CRAWL SPACE	135		46.22	6,239				
												F22	O	FPL 2S 2OP	1	34,145.50	34,146		
												GFP	O	GAS LOG/FP/E FP	4	14,620.53	58,482		
												EFF.YR/AGE		2014 / 8					
												COND		8 8 %					
												FUNC		0					
												ECON		0					
												DEPR		8 % GD		92			
												RCNLD				\$3,835,100			