

Key: 6735

Town of CHATHAM - Fiscal Year 2024

9/7/2023 9:38 am SEQ #: 7.211

LEGALS

CURRENT OWNER				PARCEL ID				LOCATION			
FIELDS JANET PO BOX 1616 W CHATHAM, MA 02669-1616				8C-21-S34				40 PINE RIDGE RD			
TRANSFER HISTORY				DOS	T	SALE PRICE	BK-PG (Cert)				
FIELDS JANET				12/15/2006	A	1 (181853)					
BOOTH W FRANCIS & HELEN I				12/02/1997	A	1 (146728)					
BOOTH, W FRANCIS				08/01/1921	QS	1 156-92					

CLASS	CLASS%	DESCRIPTION		BN ID	BN	CARD	
1090	100	MULTIPLE HSES			1	1 of 2	
PMT NO	PMT DT	TY	DESC	AMOUNT	INSP	BY	1st %
17-018	01/18/2017	3	Renovations		07/20/2018	WFF	100 100
	01/07/2011	50	Meas & List			CE	100 100
	01/01/2010	50	Meas & List			CE	100 100
09-396	10/28/2009	4	Outbuildings	70,000	01/07/2011		100 100
09-395	10/28/2009	2	Additions	90,000	01/07/2011		100 100

LAND

CD	T	AC/SF/UN	Nbhd	Inf1	Inf2	ADJ BASE	SAF	Inf3	Lpi	VC	CREDIT AMT	ADJ VALUE
100	S	12,000	WC	1.00	100	1,007,875	2.74	MDW	1.10	R08	2.50	760,790

TOTAL	12,000 SF	ZONING	R20	FRNT	93	ASSESSED	CURRENT	PREVIOUS
Nbhd	WEST CHATHAM	N O T E	Booth W Fran			LAND	760,800	634,000
Inf1	100		BUILDING	445,500	410,000			
Inf2	100		DETACHED	0	0			
			OTHER	181,100	166,700			
			<b>TOTAL</b>	<b>1,387,400</b>	<b>1,210,700</b>			

DETACHED

TY	QUAL	COND	DIM/NOTE	YB	UNITS	ADJ PRICE	RCNLD

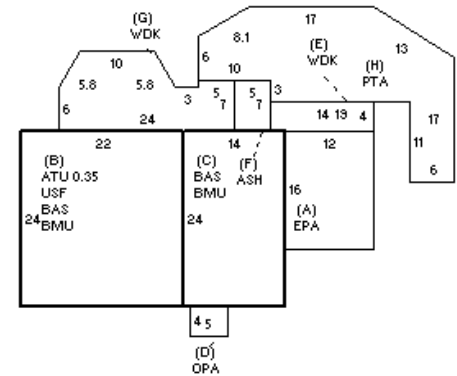

BUILDING

BUILDING	CD	ADJ	DESC	MEASURE
MODEL	1		RESIDENTIAL	LIST REVIEW
STYLE	5	1.00	COLONIAL [100%]	
QUALITY	A	1.00	AVERAGE [100%]	
FRAME	1	1.00	WOOD FRAME [100%]	

BLDG COMMENTS	

G

YEAR BLT	1963	SIZE ADJ	1.000	ELEMENT	CD	DESCRIPTION	ADJ	S	BAT	T	DESCRIPTION	UNITS	YB	ADJ PRICE	RCN	TOTAL RCN	500,524
NET AREA	1,392	DETAIL ADJ	1.030	FOUNDATION	4	FLR & WALL	1.00	A	EPA	N	ENCL PORCH	192		133.70	25,670	CONDITION ELEM	CD
\$NLA(RCN)	\$360	OVERALL	1.000	EXT. COVER	1	WOOD SHINGLE	1.00	+	BMU	N	BSMT UNFINISHED	864		75.03	64,825	EXTERIOR	G
				ROOF SHAPE	1	GABLE	1.00	+	BAS	L	BAS AREA	864	1963	271.20	234,313	INTERIOR	G
				ROOF COVER	1	ASPH/CMP SHIN	1.00	B	USF	L	UP-STRY FIN	528	2009	230.12	121,503	KITCHEN	G
				FLOOR COVER	16	HARDWD/OTHER	1.00	B	ATU	N	UNFIN ATTIC	185		78.50	14,523	BATHS	G
				INT. FINISH	23	DRYWLI/WD PNL	1.00	D	OPA	N	OPEN PORCH	20		76.10	1,522	HEAT	U
				HEATING/COOL	9	WARM/COOL AIR	1.03	+	WDK	N	WOOD DECK	270		58.40	15,768	ELECT	U
				FUEL SOURCE	2	GAS	1.00	F	ASH	N	ATT SHED	35		60.60	2,121		
								H	PTA	N	PATIO/STOOP	439		17.90	7,858		
								F11	O		FPL 1S 1OP	1		7,477.00	7,477		
												EFF.YR/AGE	2011 / 11				
												COND	11 11 %				
												FUNC	0				
												ECON	0				
												DEPR	11 % GD		89		
												RCNLD			\$445,500		

