

Key: 685

Town of CHATHAM - Fiscal Year 2024

9/7/2023 9:38 am SEQ #: 772

LEGAL

CURRENT OWNER				PARCEL ID				LOCATION				
LOIS R ROSEN 2008 REVOCABLE TRUST ROSEN HERBERT C & LOIS R TRSTES 28 BREWSTER RD SUDBURY, MA 01776				11E-46-D7				88 THE CORNFIELD				
TRANSFER HISTORY				DOS	T	SALE PRICE	BK-PG (Cert)					
LOIS R ROSEN 2008 REVOCAB				07/07/2010	QS	677,500	24665-309					
PARKER RONALD R & CAROLYN				02/02/2000	QS	314,500	12812-273					
TRIMBLE LINDA B				07/11/1989	A	1	6802-76					

CLASS	CLASS%	DESCRIPTION			BN ID	BN	CARD	
1010	100	SINGLE FAMILY				1	1 of 1	
PMT NO	PMT DT	TY	DESC	AMOUNT	INSP	BY	1st	%
21-623	07/14/2021	11	Window Rplc	18,000	04/29/2022	NF	100	100
	02/19/2005	50	Meas & List			RRC	100	100
000000437	06/24/2004	2	Additions	35,000			100	100
P2004322	06/17/2004	2	Additions	5,875			100	100
000000243	04/08/2004	10	Reroof	17,000			100	100

LAND

CD	T	AC/SF/UN	Nbhd	Inf1	Inf2	ADJ BASE	SAF	Inf3	Lpi	VC	CREDIT AMT	ADJ VALUE
100	S	13,417	WC	1.00	100	1.00	100	1.00	R06	1.75		492,100

TOTAL	13,417 SF	ZONING	R20	FRNT	80	ASSESSED	CURRENT	PREVIOUS
Nbhd	WEST CHATHAM	NOTE			LAND	492,100	410,100	
Inf1	100		BUILDING	683,600	630,300			
Inf2	100		DETACHED	0	0			
			OTHER	0	0			
TOTAL						1,175,700	1,040,400	

DETACHED

TY	QUAL	COND	DIM/NOTE	YB	UNITS	ADJ PRICE	RCNLD	PHOTO
								04/29/2022



BUILDING	CD	ADJ	DESC	MEASURE		
MODEL	1		RESIDENTIAL	LIST		
STYLE	4	1.00	CAPE [100%]	REVIEW	5/11/2022	MR
QUALITY	+	1.20	PLUS AVE [100%]			
FRAME	1	1.00	WOOD FRAME [100%]			

BUILDING

YEAR BLT	1980	SIZE ADJ	1.000	ELEMENT	CD	DESCRIPTION	ADJ	S	BAT	T	DESCRIPTION	UNITS	YB	ADJ PRICE	RCN	TOTAL RCN	911,486
NET AREA	2,242	DETAIL ADJ	1.050	FOUNDATION	4	FLR & WALL	1.00	A	AGR	N	ATTACHED GARAGE	396		96.68	38,284		
\$NLA(RCN)	\$407	OVERALL	1.000	EXT. COVER	1	WOOD SHINGLE	1.00	+	BMU	N	BSMT UNFINISHED	1,484		80.35	119,234		
				ROOF SHAPE	1	GABLE	1.00	+	BAS	L	BAS AREA	1,220	1980	302.52	369,073		
				ROOF COVER	1	ASPH/CMP SHIN	1.00	D	USF	L	UP-STRY FIN	714	1980	256.70	183,282		
				FLOOR COVER	23	SOFTWD/CARPET	1.00	+	WDK	N	WOOD DECK	832		70.08	58,307		
				INT. FINISH	2	DRYWALL	1.00	G	OSP	N	OPEN SCR PORCH	168		94.56	15,886		
				HEATING/COOL	11	HT-WT/COOL AIR	1.05	H	PTA	N	PATIO/STOOP	256		21.48	5,498		
				FUEL SOURCE	2	GAS	1.00	I	BAS	L	BAS AREA	308	2002	302.52	93,176		
									F21	O	FPL 2S 1OP	1		12,451.20	12,451		
									GFP	O	GAS LOG/FP/E FP	1		7,466.40	7,466		
									ODS	O	OUT DOOR SHWR-A	1		1,772.40	1,772		

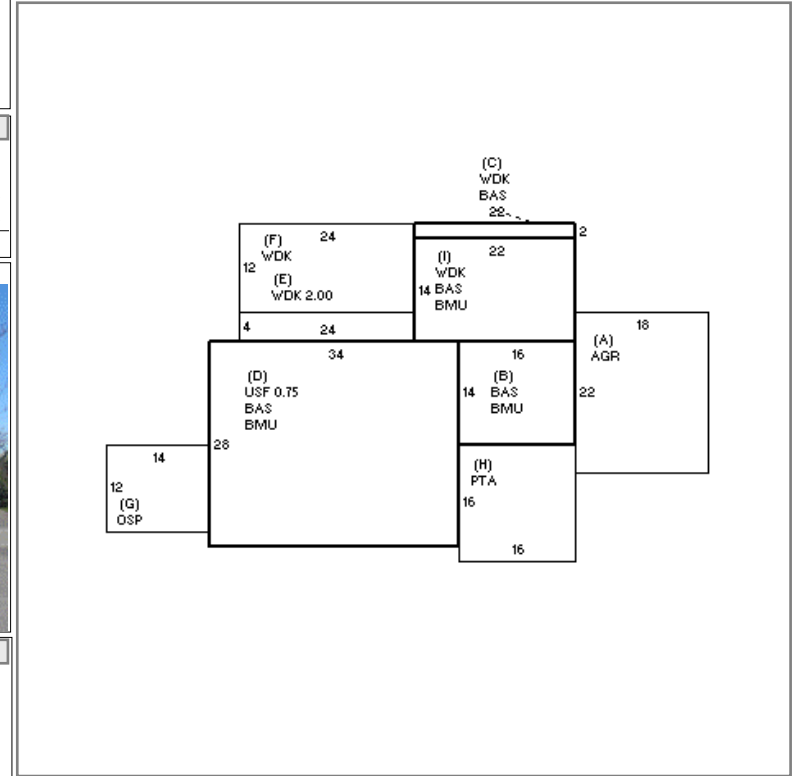

CONDITION ELEM	CD	
EXTERIOR	A	
INTERIOR	G	
KITCHEN	A	
BATHS	A	
HEAT	A	
ELECT	A	
EFF.YR/AGE	1988 / 34	
COND	25	25 %
FUNC	0	
ECON	0	
DEPR	25	% GD 75
RCNLD		\$683,600