

Key: 688

Town of CHATHAM - Fiscal Year 2024

9/7/2023 9:38 am SEQ #: 775

LEGAL

LAND

DETACHED

BUILDING

CURRENT OWNER				PARCEL ID				LOCATION			
THE ESTABROOK REVOC TRUST ESTABROOK JAMES E & LYNN M COTRSTES 59 THE CORNFIELD CHATHAM, MA 02633				11E-49-D10				59 THE CORNFIELD			
TRANSFER HISTORY				DOS	T	SALE PRICE	BK-PG (Cert)				
THE ESTABROOK REVOC TRUST				04/06/2021	A	1	33984-100				
ESTABROOK JAMES E & LYNN				05/09/1999	99	205,000	12241-15				
N/A				01/01/1987	A	1	3502-200				

CLASS	CLASS%	DESCRIPTION		BN ID	BN	CARD	
1010	100	SINGLE FAMILY			1	1 of 1	
PMT NO	PMT DT	TY	DESC	AMOUNT	INSP	BY	1st %
18-528	07/09/2018	7	No permit		02/25/2019	TCK	100 100
	04/04/2007	50	SOLAR PANELS Meas & List	7,125	02/25/2019	TCK RRC	100 100

CD	T	AC/SF/UN	Nbhd	Inf1	Inf2	ADJ BASE	SAF	Inf3	Lpi	VC	CREDIT AMT	ADJ VALUE	
100	S	14,715	WC	1.00	1.00	1.00	1.00	641,375	2.30	100	1.00	R06 1.75	498,870

TOTAL	14,715 SF	ZONING	R20	FRNT	100	ASSESSED	CURRENT	PREVIOUS
Nbhd	WEST CHATHAM	NOTE			LAND	498,900	415,700	
Inf1	100		BUILDING	444,100	404,200			
Inf2	100		DETACHED	0	0			
			OTHER	0	0			
TOTAL						943,000	819,900	

TY	QUAL	COND	DIM/NOTE	YB	UNITS	ADJ PRICE	RCNLD

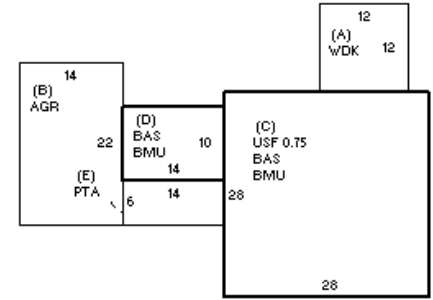

BUILDING	CD	ADJ	DESC	MEASURE		
MODEL	1		RESIDENTIAL	LIST REVIEW	6/4/2019	TD
STYLE	4	1.00	CAPE [100%]			
QUALITY	+	1.20	PLUS AVE [100%]			
FRAME	1	1.00	WOOD FRAME [100%]			

BLDG COMMENTS
12 SOLAR PANELS

YEAR BLT	1981	SIZE ADJ	1.000	ELEMENT	CD	DESCRIPTION	ADJ	S	BAT	T	DESCRIPTION	UNITS	YB	ADJ PRICE	RCN	TOTAL RCN	608,380
NET AREA	1,512	DETAIL ADJ	1.050	FOUNDATION	4	FLR & WALL	1.00	A	WDK	N	WOOD DECK	144		70.08	10,092		
\$NLA(RCN)	\$402	OVERALL	1.000	EXT. COVER	1	WOOD SHINGLE	1.00	B	AGR	N	ATTACHED GARAGE	308		100.43	30,934		
				ROOF SHAPE	1	GABLE	1.00	+	BMU	N	BSMT UNFINISHED	924		88.53	81,803		
				ROOF COVER	1	ASPH/CMP SHIN	1.00	+	BAS	L	BAS AREA	924	1981	325.72	300,962		
				FLOOR COVER	23	SOFTWD/CARPET	1.00	C	USF	L	UP-STRY FIN	588	1981	276.38	162,512		
				INT. FINISH	2	DRYWALL	1.00	E	PTA	N	PATIO/STOOP	84		21.49	1,805		
				HEATING/COOL	11	HT-WT/COOL AIR	1.05	F21	O	FPL 2S 1OP	1			12,451.20	12,451		
				FUEL SOURCE	2	GAS	1.00	ODS	O	OUT DOOR SHWR-A	1			1,772.40	1,772		

CONDITION ELEM	CD
EXTERIOR	
INTERIOR	
KITCHEN	
BATHS	
HEAT	
ELECT	

EFF.YR/AGE	1982 / 40
COND	27 27 %
FUNC	0
ECON	0
DEPR	27 % GD 73
RCNLD	\$444,100