

Key: 7237

Town of CHATHAM - Fiscal Year 2024

9/7/2023 9:38 am SEQ #: 7.721

LEG
AL
L
A
N
D

CURRENT OWNER				PARCEL ID				LOCATION							
300CHATHAM REAL ESTATE LLC 50 MT VERNON ST CAMBRIDGE, MA 02140-2711				9A-10-3				300 STAGE NECK RD							
TRANSFER HISTORY				DOS	T	SALE PRICE	BK-PG (Cert)								
300CHATHAM REAL ESTATE LL				10/28/2021	QS	13,000,000	(228030)								
DAWN P WEBERT 2012 QPRT				12/12/2012	A	1	(198958)								
WEBER LAWRENCE & DAWN P T				05/15/1998	QS	2,900,000	(148527)								
CD	T	AC/SF/UN	Nbhd	Inf1	Inf2	ADJ BASE	SAF	Inf3	Lpi	VC	CREDIT AMT	ADJ VALUE			
100	S	40,000	CH	1.00	100	1.00	100	1.00	4,434,650	1.00	MDW	1.10	CF5	11.00	4,072,220
300	A	2,491	CH	1.00	100	1.00	100	1.00	211,200	1.00	100	1.00	CF5	11.00	526,100
300	A	1,820	CH	1.00	25	0.25	100	1.00	52,800	1.00	100	1.00	CF5	11.00	96,100

CLASS	CLASS%	DESCRIPTION			BN ID	BN	CARD	
1090	100	MULTIPLE HSES				1	1 of 2	
PMT NO	PMT DT	TY	DESC	AMOUNT	INSP	BY	1st	%
2003117	10/23/2003	99	n/a				100	100
	01/28/2003	50	Meas & List			JB	100	100
P2002003	01/03/2002	2	Additions	54,950			100	100
SP01-96	11/29/2001	99	n/a				100	100
2000233	06/28/2000	99	n/a				100	100

TOTAL	5.229 Acres	ZONING	R40	FRNT	0	ASSESSED	CURRENT	PREVIOUS
Nbhd	CHATHAM	N O T E	Harbor Front/conservation restriction in perpetuity			LAND	4,694,400	3,911,800
Inf1	100		BUILDING	6,194,600	5,536,200			
Inf2	100		DETACHED	86,300	82,200			
			OTHER	921,200	795,200			
			TOTAL	11,896,500	10,325,400			

TY	QUAL	COND	DIM/NOTE	YB	UNITS	ADJ PRICE	RCNLD	
IPC	G	1.20	10 0.90	Wbuilt in Wp	2000	880	48.92	38,700
CAB	S	3.00	10 0.90	w full bsmt	2000	120	269.63	29,100
WDK	A	1.00	10 0.90	BP02-003 BOA	2002	1,099	16.60	16,400
STR	G	1.20	10 0.90	16X4	2002	64	36.00	2,100



BLDG COMMENTS
 BMF=1BDRM,1F.BATH,1RM,.5BTH 12/13/12 -
 GATED NO ACCESS

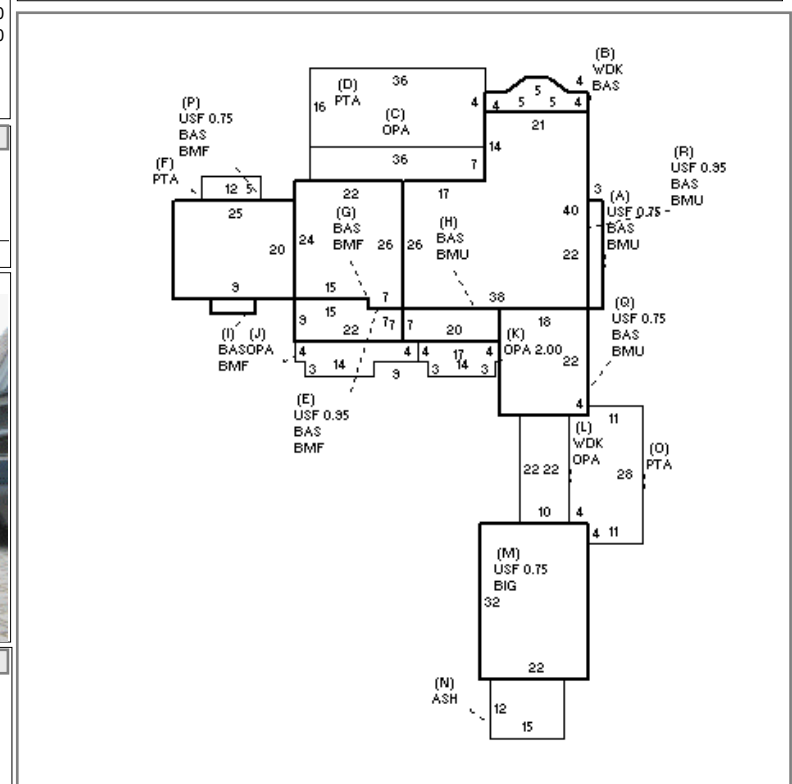

D
E
T
A
C
H
E
D

BUILDING	CD	ADJ	DESC	MEASURE		
MODEL	1		RESIDENTIAL	LIST REVIEW	11/13/2018	APK
STYLE	19	1.30	NEW STYLE [100%]			
QUALITY	E	3.50	EXCELLENT [100%]			
FRAME	1	1.00	WOOD FRAME [100%]			

B
U
I
L
D
I
N
G

YEAR BLT	2001	SIZE ADJ	1.000	ELEMENT	CD	DESCRIPTION	ADJ	S	BAT	T	DESCRIPTION	UNITS	YB	ADJ PRICE	RCN	TOTAL RCN	7,647,686					
NET AREA	6,230	DETAIL ADJ	1.352	FOUNDATION	4	FLR & WALL	1.00	+	BMU	N	BSMT UNFINISHED	1,884		225.82	425,439							
\$NLA(RCN)	\$1,228	OVERALL	1.000	EXT. COVER	1	WOOD SHINGLE	1.00	+	USF	L	UP-STRY FIN	2,982	2001	865.81	2,581,859							
				ROOF SHAPE	1	GABLE	1.00	+	BAS	L	BAS AREA	3,248	2001	1,020.37	3,314,150							
				ROOF COVER	2	WOOD SHIN	1.01	+	WDK	N	WOOD DECK	331		204.40	67,655							
				FLOOR COVER	16	HARDWD/OTHER	1.00	+	OPA	N	OPEN PORCH	834		266.35	222,135							
				INT. FINISH	23	DRYWLI/WD PNL	1.00	+	PTA	N	PATIO/STOOP	1,032		62.65	64,656							
				HEATING/COOL	9	WARM/COOL AIR	1.03	+	BMF	N	BSMT FINISH-SEP	1,253		380.10	476,266							
				FUEL SOURCE	2	GAS	1.00	M	BIG	N	BUILT-IN GARAGE	704		265.22	186,715							
													N	ASH	N	ATT SHED	180		212.10	38,178		
														F22	O	FPL 2S 2OP	2		50,855.00	101,710		
														GFP	O	GAS LOG/FP/E FP	3		21,775.83	65,328		
														ODS	O	OUT DOOR SHWR-A	1		5,169.50	5,170		
																CONDITION ELEM	CD					
																EXTERIOR						
																INTERIOR						
																KITCHEN						
																BATHS						
																HEAT						
																ELECT						
																EFF.YR/AGE	2003 / 19					
																COND	19	19 %				
																FUNC	0					
																ECON	0					
																DEPR	19	% GD 81				
																RCNLD		\$6,194,600				

Key: 7237

Town of CHATHAM - Fiscal Year 2024

9/7/2023 9:38 am SEQ #: 7.722

LEGAL

CURRENT OWNER		PARCEL ID		LOCATION	
300CHATHAM REAL ESTATE LLC 50 MT VERNON ST CAMBRIDGE, MA 02140-2711		9A-10-3		300 STAGE NECK RD	
TRANSFER HISTORY		DOS	T	SALE PRICE	BK-PG (Cert)

CLASS	CLASS%	DESCRIPTION			BN ID	BN	CARD
1090	100	MULTIPLE HSES				2	2 of 2
PMT NO	PMT DT	TY	DESC	AMOUNT	INSP	BY	1st %

LAND

CD	T	AC/SF/UN	Nbhd	Inf1	Inf2	ADJ BASE	SAF	Inf3	Lpi	VC	CREDIT AMT	ADJ VALUE
----	---	----------	------	------	------	----------	-----	------	-----	----	------------	-----------

DETACHED

TOTAL	ZONING	FRNT	ASSESSED	CURRENT	PREVIOUS
Nbhd	NOTE		LAND	921,200	
Inf1		BUILDING			
Inf2		DETACHED			
			OTHER		
			TOTAL		

TY	QUAL	COND	DIM/NOTE	YB	UNITS	ADJ PRICE	RCNLD	PHOTO
								07/10/2013



BLDG COMMENTS
TWO FIXTURES = 2 KITCHENETTES 12/13/12 - GATED NO ACCESS

BUILDING

BUILDING	CD	ADJ	DESC	MEASURE	REVIEW	DATE	APK
MODEL	1		RESIDENTIAL	LIST			
STYLE	5	1.00	COLONIAL [100%]				
QUALITY	V	2.35	VERY GOOD [100%]				
FRAME	1	1.00	WOOD FRAME [100%]				

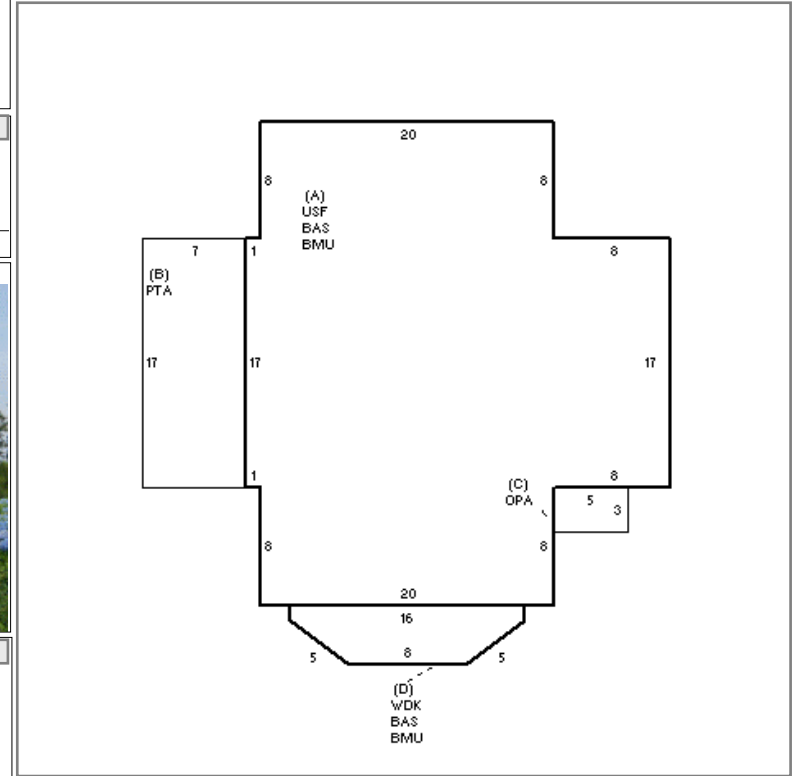

YEAR BLT	2000	SIZE ADJ	1.000
NET AREA	1,678	DETAIL ADJ	1.040
\$NLA(RCN)	\$686	OVERALL	1.000
CAPACITY		UNITS	ADJ
STORIES	2	2	1.00
ROOMS	0	0	1.00
BEDROOMS	2	2	1.00
FULL BATHS	2	2	1.00
1/2 BATHS	0	0	1.00
FIXTURES	10	\$19,552	
UNITS	1	1.00	

ELEMENT	CD	DESCRIPTION	ADJ
FOUNDATION	4	FLR & WALL	1.00
EXT. COVER	1	WOOD SHINGLE	1.00
ROOF SHAPE	1	GABLE	1.00
ROOF COVER	2	WOOD SHIN	1.01
FLOOR COVER	26	SOFTWD/OTHER	1.00
INT. FINISH	23	DRYWLI/WD PNL	1.00
HEATING/COOL	9	WARM/COOL AIR	1.03
FUEL SOURCE	2	GAS	1.00

S	BAT	T	DESCRIPTION	UNITS	YB	ADJ PRICE	RCN
+	BMU	N	BSMT UNFINISHED	865		176.15	152,374
+	BAS	L	BAS AREA	865	2000	618.23	534,766
A	USF	L	UP-STRY FIN	813	2000	524.58	426,487
B	PTA	N	PATIO/STOOP	119		42.06	5,006
C	OPA	N	OPEN PORCH	15		178.91	2,684
D	WDK	N	WOOD DECK	52		137.25	7,137
	ODS	O	OUT DOOR SHWR-A	1		3,471.00	3,471

TOTAL RCN	1,151,477
CONDITION ELEM	CD
EXTERIOR	
INTERIOR	
KITCHEN	
BATHS	
HEAT	
ELECT	
EFF.YR/AGE	2002 / 20
COND	20 20 %
FUNC	0
ECON	0
DEPR	20 % GD 80
RCNLD	\$921,200