

Key: 7313

Town of CHATHAM - Fiscal Year 2024

9/7/2023 9:38 am SEQ #: 7.804

LEGAL

LAND

DETACHED

BUILDING

CURRENT OWNER				PARCEL ID				LOCATION			
THE RALPH STANLEY MARQUIT FAMILY TRUST MARQUIT RALPH STANLEY TRUSTEE PO BOX 44 W CHATHAM, MA 02669-0044				9C-11-14				22 VALLEY FARM DR			
TRANSFER HISTORY				DOS	T	SALE PRICE		BK-PG (Cert)			
THE RALPH STANLEY MARQUIT MARQUIT RALPH S				01/21/2014	A	1 27945-128		1 3342-51			
				08/04/1981	A						

CLASS	CLASS%	DESCRIPTION			BN ID	BN	CARD	
1010	100	SINGLE FAMILY				1	1 of 1	
PMT NO	PMT DT	TY	DESC	AMOUNT	INSP	BY	1st	%
19-0579	08/27/2019	10	Reroof	8,465	02/25/2020	TCK	100	100
SS14-16	01/01/2013	20	Splits/Land			RRC	100	100
	02/09/2010	50	Meas & List				100	100
95-096	02/01/1995	99	n/a	500			100	100
1981109	07/28/1981	99	n/a				100	100

CD	T	AC/SF/UN	Nbhd	Inf1	Inf2	ADJ BASE	SAF	Inf3	Lpi	VC	CREDIT AMT	ADJ VALUE
100	S	33,339	WC	1.00	90	0.90	100	1.00	R04	1.40		410,050

TOTAL	33,339 SF	ZONING	R20	FRNT	0	ASSESSED	CURRENT	PREVIOUS
Nbhd	WEST CHATHAM	N O T E	Topo			LAND	410,100	341,700
Inf1	90		BUILDING	316,800	288,300			
Inf2	100		DETACHED	1,700	1,600			
			OTHER	0	0			
						<b>TOTAL</b>	<b>728,600</b>	<b>631,600</b>

TY	QUAL	COND	DIM/NOTE	YB	UNITS	ADJ PRICE	RCNLD
SHF	A	1.00	20 0.80	1987	180	11.98	1,700



BLDG COMMENTS

BUILDING	CD	ADJ	DESC	MEASURE
MODEL	1		RESIDENTIAL	LIST REVIEW
STYLE	4	1.00	CAPE [100%]	
QUALITY	A	1.00	AVERAGE [100%]	
FRAME	1	1.00	WOOD FRAME [100%]	
				3/11/2020 MR

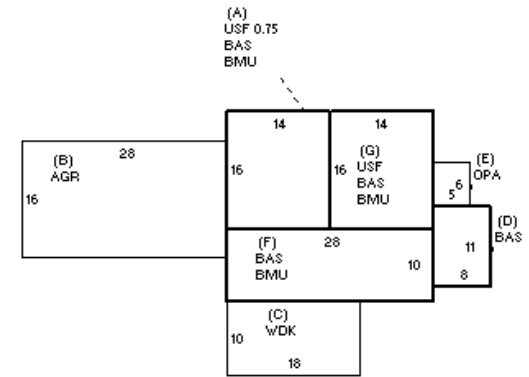

YEAR BLT	1981	SIZE ADJ	1.000	ELEMENT	CD	DESCRIPTION	ADJ	S	BAT	T	DESCRIPTION	UNITS	YB	ADJ PRICE	RCN	TOTAL RCN	433,921				
NET AREA	1,208	DETAIL ADJ	1.000	FOUNDATION	4	FLR & WALL	1.00	+	BMU	N	BSMT UNFINISHED	728		78.65	57,256	CONDITION ELEM	CD				
\$NLA(RCN)	\$359	OVERALL	1.000	EXT. COVER	1	WOOD SHINGLE	1.00	+	USF	L	UP-STRY FIN	392	1981	231.33	90,683	EXTERIOR	A				
				ROOF SHAPE	6	SALTBOX	1.00	B	AGR	N	ATTACHED GARAGE	448		79.34	35,546	INTERIOR	A				
				ROOF COVER	1	ASPH/CMP SHIN	1.00	C	WDK	N	WOOD DECK	180		58.40	10,512	KITCHEN	A				
				FLOOR COVER	3	W/W CARPET	1.00	+	BAS	L	BAS AREA	816	1981	272.63	222,465	BATHS	A				
				INT. FINISH	2	DRYWALL	1.00	E	OPA	N	OPEN PORCH	30		76.10	2,283	HEAT	A				
				HEATING/COOL	1	FORCED AIR	1.00	F21	O		FPL 2S 1OP	1		10,376.00	10,376	ELECT	A				
				FUEL SOURCE	1	OIL	1.00														
																		EFF.YR/AGE	1981 / 41		
																		COND	27 27 %		
																		FUNC	0		
																		ECON	0		
																		DEPR	27	% GD	73
																		RCNLD	\$316,800		