

Key: 7414

Town of CHATHAM - Fiscal Year 2024

9/7/2023 9:38 am SEQ #: 7.906

LEGAL

CURRENT OWNER				PARCEL ID				LOCATION			
BELLO J WILLIAM & REGINA M 16009 BACONSFIELD LN MARYLAND, MD 21111				9D-31E-X5				48 YOUNGS RD			
TRANSFER HISTORY				DOS	T	SALE PRICE	BK-PG (Cert)				
BELLO J WILLIAM & REGINA				11/04/2013	QS	380,000	27803-310				
BOMBARD CLIFFORD E & C PA				08/08/1983	QS	50,000	3823-106				
MCCANDLESS				06/01/1980	N	29,000	3110-190				

CLASS	CLASS%	DESCRIPTION			BN ID	BN	CARD
1020	100	CONDOMINIUM				1	1 of 1
PMT NO	PMT DT	TY	DESC	AMOUNT	INSP	BY	1st %
01-214	04/18/2001	99	n/a	40,000			100 100

LAND

CD	T	AC/SF/UN	Nbhd	Inf1	Inf2	ADJ BASE	SAF	Inf3	Lpi	VC	CREDIT AMT	ADJ VALUE

TOTAL	SF	ZONING	R20	FRNT	0	ASSESSED	CURRENT	PREVIOUS
Nbhd		NOTE				LAND	0	0
Inf1						BUILDING	604,200	493,200
Inf2						DETACHED	0	0
						OTHER	0	0
						<b>TOTAL</b>	<b>604,200</b>	<b>493,200</b>

DETACHED

TY	QUAL	COND	DIM/NOTE	YB	UNITS	ADJ PRICE	RCNLD	PHOTO
								07/01/2016

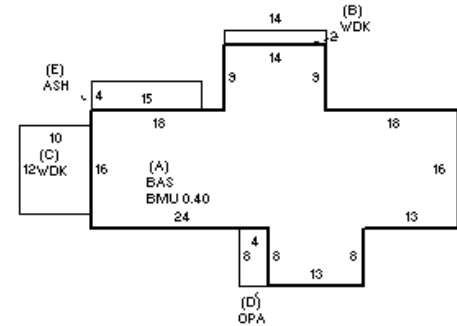

BUILDING

BUILDING	CD	ADJ	DESC	MEASURE	7/1/2016	WFF
MODEL	10		CONDO	LIST	7/1/2016	EST
STYLE	2	1.00	FREE STANDING [100%]	REVIEW	9/30/2016	APK
QUALITY	A	1.00	AVERAGE [100%]			
FRAME	99	1.00	N/A [100%]			

BLDG COMMENTS

G

YEAR BLT	1952	SIZE ADJ	1.000	ELEMENT	CD	DESCRIPTION	ADJ	S	BAT	T	DESCRIPTION	UNITS	YB	ADJ PRICE	RCN	TOTAL RCN	686,625																	
NET AREA	1,030	DETAIL ADJ	2.205	COMPLEX	64	PINEHILL COTTAG	2.25	A	BMU	N	BSMT UNFINISHED	412		23.00	9,476	CONDITION ELEM	CD																	
\$NLA(RCN)	\$667	OVERALL	1.000	UNIT MODEL	99	N/A	1.00	A	BAS	L	BAS AREA	1,030	1952	644.26	663,588	INTERIOR	G																	
				VIEW/LOC	1	NONE	1.00	+	WDK	N	ATT WOOD DECK	148		19.00	2,812	KITCHEN	G																	
				HVAC	6	GRAVITY	0.98	D	OPA	N	OPEN PORCH	32		24.91	797	BATHS	G																	
				FUEL SOURCE	3	ELECTRIC	1.00	E	ASH	N	ATT SHED	60		13.20	792	EXTERIOR	G																	
				FLOOR LEVEL	99	N/A	1.00	GFP	O		GAS LOG/FP/E FP	1		2,846.00	2,846																			
				NEIGHBORHOOD	5	WEST	1.00	ODS	O		OUT DOOR SHWR-A	1		1,022.00	1,022																			
<table border="1" style="width: 100%;"> <tr> <td>EFF.YR/AGE</td> <td colspan="2">1983 / 39</td> </tr> <tr> <td>COND</td> <td>12</td> <td>12 %</td> </tr> <tr> <td>FUNC</td> <td>0</td> <td></td> </tr> <tr> <td>ECON</td> <td>0</td> <td></td> </tr> <tr> <td>DEPR</td> <td>12</td> <td>% GD 88</td> </tr> <tr> <td>RCNLD</td> <td colspan="2">\$604,200</td> </tr> </table>																	EFF.YR/AGE	1983 / 39		COND	12	12 %	FUNC	0		ECON	0		DEPR	12	% GD 88	RCNLD	\$604,200	
EFF.YR/AGE	1983 / 39																																	
COND	12	12 %																																
FUNC	0																																	
ECON	0																																	
DEPR	12	% GD 88																																
RCNLD	\$604,200																																	