

Key: 7472

Town of CHATHAM - Fiscal Year 2024

9/7/2023 9:38 am SEQ #: 7.972

LEGAL

LAND

DETAILED

BUILDING

CURRENT OWNER				PARCEL ID				LOCATION			
CHATHAM APARTMENTS LLC 325 FOX HILL RD CHATHAM, MA 02633				9E-70-6AA				20 WHELDON WAY			
TRANSFER HISTORY				DOS	T	SALE PRICE	BK-PG (Cert)				
CHATHAM APARTMENTS LLC				03/27/2020	V	1,699,000	32789-244				
1532 MAIN STREET LLC				02/15/2013	V	989,500	27135-186				
ROCHETTE RICHARD & GLORIA				02/22/2003	A	1	16438-327				

CLASS	CLASS%	DESCRIPTION			BN ID	BN	CARD	
1110	100	4 TO 8 UNITS				1	1 of 1	
PMT NO	PMT DT	TY	DESC	AMOUNT	INSP	BY	1st	%
22-305	04/21/2022	99	n/a	3,750			0	0
21-572	08/23/2021	14	DECK	5,200			0	0
	05/21/2009	62	-			CE	100	100

CD	T	AC/SF/UN	Nbhd	Inf1	Inf2	ADJ BASE	SAF	Inf3	Lpi	VC	CREDIT AMT	ADJ VALUE
103	S	19,791	CI	1.00	100	375,210	1.72	100	1.00	OUT	0.90	293,310

TOTAL	19,791 SF	ZONING	R20	FRNT	152	ASSESSED	CURRENT	PREVIOUS
Nbhd	COMMERCIAL	NOTE				LAND	293,300	266,700
Inf1	100		BUILDING	790,500	729,100			
Inf2	100		DETACHED	2,900	2,700			
			OTHER	0	0			
						TOTAL	1,086,700	998,500

TY	QUAL	COND	DIM/NOTE	YB	UNITS	ADJ PRICE	RCNLD
APV	A	1.00	70 0.30	1988	4,800	2.00	2,900

PHOTO 06/13/2022



BLDG COMMENTS
WEATHERBOARDS/6 UNITS

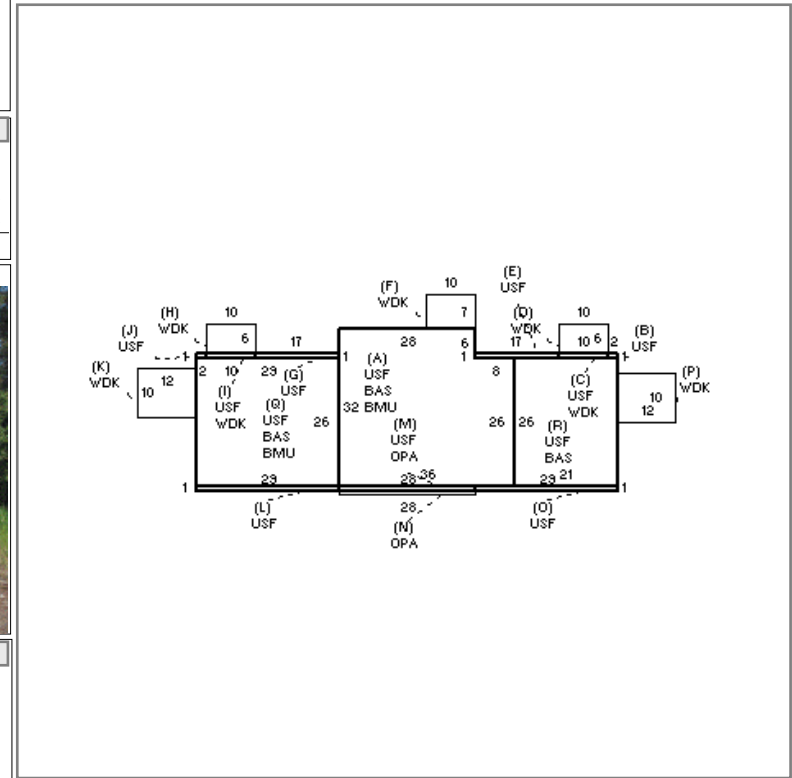

BUILDING	CD	ADJ	DESC	MEASURE	4/9/2019	APK
MODEL	1		RESIDENTIAL	LIST		
STYLE	20	0.85	APARTMENTS [100%]	REVIEW	4/9/2019	APK
QUALITY	A	1.00	AVERAGE [100%]			
FRAME	1	1.00	WOOD FRAME [100%]			

YEAR BLT	1976	SIZE ADJ	1.000	ELEMENT	CD	DESCRIPTION	ADJ	S	BAT	T	DESCRIPTION	UNITS	YB	ADJ PRICE	RCN
NET AREA	4,952	DETAIL ADJ	0.850	FOUNDATION	4	FLR & WALL	1.00	+	BMU	N	BSMT UNFINISHED	1,858		67.24	124,940
\$NLA(RCN)	\$213	OVERALL	1.040	EXT. COVER	2	CLAPBOARD	1.00	+	USF	L	UP-STRY FIN	2,548	1976	164.39	418,876
				ROOF SHAPE	1	GABLE	1.00	+	WDK	N	WOOD DECK	450		60.74	27,331
				ROOF COVER	1	ASPH/CMP SHIN	1.00	+	OPA	N	OPEN PORCH	56		79.15	4,433
				FLOOR COVER	32	CARPET/SOFTWD	1.00	+	BAS	L	BAS AREA	2,404	1976	193.74	465,748
				INT. FINISH	2	DRYWALL	1.00								
				HEATING/COOL	5	ELECTRIC BB	1.00								
				FUEL SOURCE	3	ELECTRIC	1.00								

TOTAL RCN	1,054,058
CONDITION ELEM	CD
EXTERIOR	
INTERIOR	
KITCHEN	
BATHS	
HEAT	
ELECT	
EFF.YR/AGE	1990 / 32
COND	25 25%
FUNC	0
ECON	0
DEPR	25 % GD 75
RCNLD	\$790,500