

Key: 2107

Town of TRURO - Fiscal Year 2024

9/27/2023 7:11 pm SEQ #: 2.143

LEGALS

LAND

Table with columns: CURRENT OWNER, PARCEL ID, LOCATION, TRANSFER HISTORY, DOS, T, SALE PRICE, BK-PG (Cert), ADJ BASE, SAF, Inf1, Inf2, Inf3, Lpi, VC, CREDIT AMT, ADJ VALUE.

Table with columns: CLASS, CLASS%, DESCRIPTION, BN ID, BN, CARD, PMT NO, PMT DT, TY, DESC, AMOUNT, INSP, BY, 1st, %.

Table with columns: TOTAL, 36,591 SF, ZONING, RES, FRNT, 0, ASSESSED, CURRENT, PREVIOUS.

Table with columns: TY, QUAL, COND, DIM/NOTE, YB, UNITS, ADJ PRICE, RCNLD.

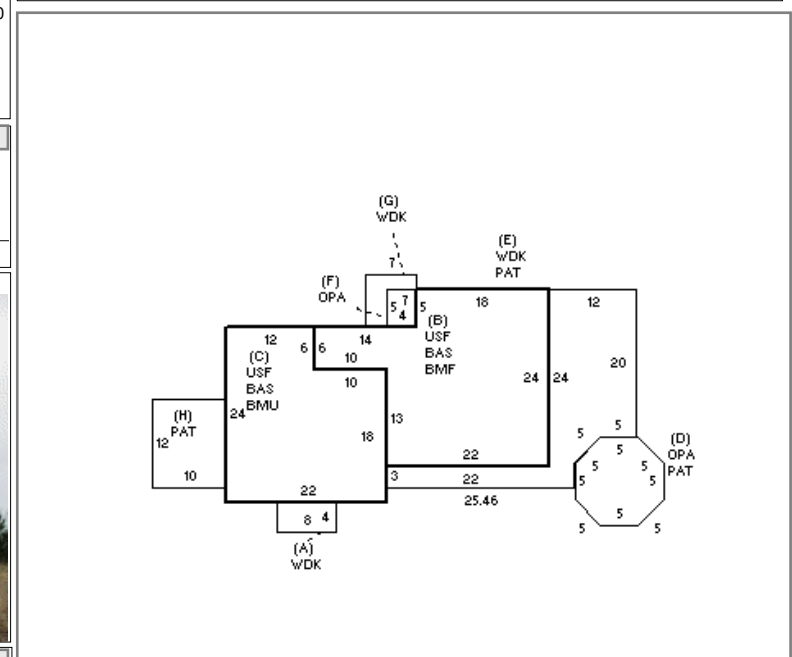

Table with columns: BUILDING, CD, ADJ, DESC, MEASURE, LIST, REVIEW.

BLDG COMMENTS: OPA=GAZEBO ON 2ND FLR WDK.

DETAILED

BUILDING

Main summary table with columns: YEAR BLT, NET AREA, \$NLA(RCN), CAPACITY, UNITS, ADJ, ELEMENT, CD, DESCRIPTION, ADJ, S, BAT, T, DESCRIPTION, UNITS, YB, ADJ PRICE, RCN, TOTAL RCN, CONDITION ELEM, CD, EFF. YR/AGE, COND, FUNC, ECON, DEPR, RCNLD.

Key: 2107

Town of TRURO - Fiscal Year 2024

9/27/2023 7:11 pm SEQ #: 2.144

LEGAL

CURRENT OWNER				PARCEL ID				LOCATION			
B M W NOMINEE TRUST				45-21-0				16 CORN HILL LNDG			
TRS: MONDANO FRANK & WALLER ALL				TRANSFER HISTORY		DOS	T	SALE PRICE	BK-PG (Cert)		
PO BOX 520											
TRURO, MA 02666											

CLASS	CLASS%	DESCRIPTION			BN ID	BN	CARD	
1010	100	SINGLE FAMILY				2	2 of 2	
PMT NO	PMT DT	TY	DESC	AMOUNT	INSP	BY	1st	%

LAND

CD	T	AC/SF/UN	Nbhd	Infl1	Infl2	ADJ BASE	SAF	Infl3	Lpi	VC	CREDIT AMT	ADJ VALUE

TOTAL	ZONING	FRNT	ASSESSED	CURRENT	PREVIOUS
Nbhd	NOTE		LAND	137,600	
Infl1		BUILDING			
Infl2		DETACHED			
			OTHER		
			TOTAL		

DETACHED

TY	QUAL	COND	DIM/NOTE	YB	UNITS	ADJ PRICE	RCNLD

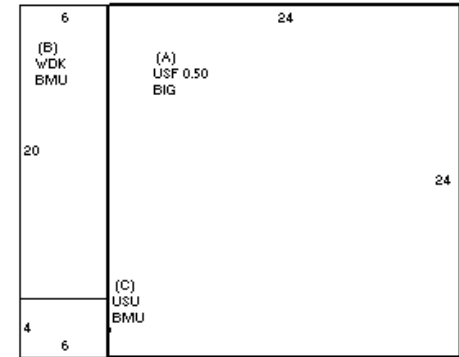

BUILDING

BUILDING	CD	ADJ	DESC	MEASURE	12/20/2016
MODEL	1		RESIDENTIAL	LIST	
STYLE	17	1.00	GAR W/QTRS [100%]	REVIEW	
QUALITY	+	1.15	GOOD-AVE+ [100%]		
FRAME	1	1.00	WOOD FRAME [100%]		

BLDG COMMENTS
12/20/16 Left door tag for List.

G

YEAR BLT	2016	SIZE ADJ	1.000	ELEMENT	CD	DESCRIPTION	ADJ	S	BAT	T	DESCRIPTION	UNITS	YB	ADJ PRICE	RCN	TOTAL RCN	146,395
NET AREA	288	DETAIL ADJ	1.000	FOUNDATION	2	SLAB	0.95	A	BIG	N	BUILT-IN GARAGE	576		80.85	46,572	CONDITION ELEM	
\$NLA(RCN)	\$508	OVERALL	0.950	EXT. COVER	1	WOOD SHINGLES	1.00	A	USF	L	UP-STRY FIN	288	2016	262.52	75,605	CD	
CAPACITY		UNITS	ADJ	ROOF SHAPE	1	GABLE	1.00	+	BMU	N	BSMT UNFINISHED	144		89.24	12,851		
STORIES(FAR)	1	1.00		ROOF COVER	1	ASPHALT SHINGLE	1.00	B	WDK	N	ATT WOOD DECK	120		65.66	7,879		
ROOMS	1	1.00		FLOOR COVER	0		1.00	C	USU	N	UPPER STORY UNF	24		145.30	3,487		
BEDROOMS	0	1.00		INT. FINISH	0		1.00										
BATHROOMS	0	1.00		HEATING/COOLING	0		1.00										
FIXTURES	0	1.00		FUEL SOURCE	0		1.00										
UNITS	0	1.00															
																EFF.YR/AGE	2016 / 6
																COND	06 06%
																FUNC	0
																ECON	0
																DEPR	6 % GD 94
																RCNLD	\$137,600